



ESM-9900 96 x 96 1/4 DIN Universal Input Process Indicator with Smart Output Module System

- 4 digits Process (PV) Display
- Universal Process Input (TC, RTD, mV_{---} , V_{---} , mA_{---})
- Dual or Multi Point Calibration for $---$ Voltage / Current Input
- Smart Output Module System
- Programmable Alarm Functions
- Retransmission of Process Value or Process Control by Using
0/4...20 mA_{---} Current Output Module
- Hardware Configuration With Output Modules
- RS-232 (standard) or RS-485 (optional) Serial Communication
With Modbus RTU Protocol

ABOUT INSTRUCTION MANUAL

Instruction manual of ESM-9900 Process Indicator consists of two main sections. Explanation of these sections are below. Also, there are other sections which include order information and technical specifications of the device. All titles and page numbers in instruction manual are in “**CONTENTS**” section. User can reach to any title with section number.

Installation:

In this section, physical dimensions of the device, panel mounting, electrical wiring, module mounting in the device, physical and electrical installation of the device to the system are explained.

Operation and Parameters:

In this section, user interface of the device, how to access to the parameters, description of parameters are explained.

Also in these sections, there are warnings to prevent serious injury while doing the physical and electrical mounting or using the device.

Explanation of the symbols which are used in these sections are given below.



This symbol is used for safety warnings. User must pay attention to these warnings.



This symbol is used to determine the dangerous situations as a result of an electric shock. User must pay attention to these warnings definitely.



This symbol is used to determine the important notes about functions and usage of the device.

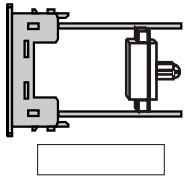

In parameters section, for making relevant parameters to be active, determined module must be installed to Module-1 or Module-2 socket.

CONTENTS

1.PREFACE	Page	6
1.1 GENERAL SPECIFICATIONS		
1.2 ORDERING INFORMATION		
1.3 WARRANTY		
1.4 MAINTENANCE		
2.INSTALLATION	Page	9
2.1 GENERAL DESCRIPTION		
2.2 DIMENSIONS		
2.3 PANEL CUT-OUT		
2.4 ENVIRONMENTAL RATINGS		
2.5 PANEL MOUNTING		
2.6 INSTALLATION FIXING CLAMP		
2.7 REMOVING FROM THE PANEL		
3.ELECTRICAL WIRINGS	Page	14
3.1 TERMINAL LAYOUT AND CONNECTION INSTRUCTION		
3.2 ELECTRICAL WIRING DIAGRAM		
3.3 SUPPLY VOLTAGE INPUT CONNECTION OF THE DEVICE		
3.4 PROCESS INPUT CONNECTION		
3.4.1 TC (THERMOCOUPLE) CONNECTION		
3.4.2 RTD CONNECTION		
3.4.3 PROCESS INPUT CONNECTION OF SERIAL TRANSMITTERS WITH CURRENT OUTPUT (LOOP POWERED)		
3.4.4 PROCESS INPUT CONNECTION OF 3-WIRE TRANSMITTERS WITH CURRENT OUTPUT		
3.4.5 CONNECTION OF TRANSMITTERS WITH VOLTAGE OUTPUT TO PROCESS INPUT		
3.5 RELAY OUTPUT CONNECTION		
3.6 GALVANIC ISOLATION TEST VALUES OF ESM-9900 PROCESS INDICATOR AND OUTPUT MODULES		
4.DEFINITIONS AND SPECIFICATIONS OF MODULES	Page	21
4.1 OUTPUT MODULES		
4.1.1 EMO-900 RELAY OUTPUT MODULE		
4.1.2 EMO-910 SSR DRIVER OUTPUT MODULE		
4.1.3 EMO-920 DIGITAL (TRANSISTOR) OUTPUT MODULE		
4.1.4 EMO-930 0/4 ...20mA== CURRENT OUTPUT MODULE		
4.2 INSTALLING AND PULLING OUT OUTPUT MODULES		
4.3 TO STICK OUTPUT MODULES' LABELS TO THE DEVICE		
5.CONNECTION TERMINALS OF OUTPUT MODULES AND CONNECTION WIRINGS	Page	27
5.1 CONNECTION WIRINGS FOR OUTPUT MODULES		
5.1.1 EMO-900 RELAY OUTPUT MODULE CONNECTION		
5.1.2 EMO-910 SSR DRIVER OUTPUT MODULE CONNECTION		
5.1.3 EMO-920 DIGITAL (TRANSISTOR) OUTPUT MODULE CONNECTION		
5.1.4 EMO-930 0/4 ...20mA== CURRENT OUTPUT MODULE CONNECTION		
5.1.5 TO GET 0...10V== WITH EMO-930 0/4 ...20mA== CURRENT OUTPUT MODULE		
6.CONNECTIONS FOR RS-232 / RS-485 SERIAL COMMUNICATION	Page	30
6.1 CABLE CONNECTION BETWEEN RS-232 TERMINAL OF THE DEVICE AND PC		
6.2 CONNECTION FOR RS-485 SERIAL COMMUNICATION		
6.3 INSTALLING RS-232 / RS-485 SERIAL COMMUNICATION MODULES TO THE DEVICE		
7.DEFINITION OF FRONT PANEL AND ACCESSING TO THE PARAMETERS	Page	34
7.1 DEFINITION OF FRONT PANEL		
7.2 OBSERVATION OF OPTIONAL MODULES AND SOFTWARE REVISION ON THE DISPLAYS		
7.3 ADJUSTMENT OF ALARM SET VALUES		
7.4 EASY ACCESS DIAGRAM FOR TECHNICIAN PARAMETERS		
7.5 ACCESSING TO THE TECHNICIAN MENU		
7.6 CHANGING AND SAVING PARAMETERS		

8.PARAMETERS	Page	53
8.1 ALARM SET PARAMETERS		
8.2 TECHNICIAN PARAMETERS		
8.2.1 PROCESS INPUT TYPE AND RELEVANT PARAMETERS WITH PROCESS INPUT		
8.2.2 MODULE-1 CONFIGURATION PARAMETERS		
8.2.3 MODULE-2 CONFIGURATION PARAMETERS		
8.2.4 OUTPUT-3 CONFIGURATION PARAMETERS		
8.2.5 GENERAL PARAMETERS		
8.2.6 PARAMETERS FOR CONFIGURATION OF SERIAL COMMUNICATION		
8.2.7 TECHNICIAN PASSWORD		
9.FAILURE MESSAGES IN ESM-9900 PROCESS INDICATORS	Page	67
10.SPECIFICATIONS	Page	68
11.OTHER INFORMATION	Page	69

EU DECLARATION OF CONFORMITY

Manufacturer Company Name : Emko Elektronik A.S.

Manufacturer Company Address: DOSAB, Karanfil Sokak, No:6, 16369 Bursa, Turkiye

The manufacturer hereby declares that the product conforms to the following standards and conditions.

Product Name : Process Indicator

Model Number : ESM-9900

Type Number : ESM-9900

Product Category : Electrical equipment for measurement, control and laboratory use

Conforms to the following directives :

2006 / 95 / EC The Low Voltage Directive

2004 / 108 / EC The Electromagnetic Compatibility Directive

has been designed and manufactured to the following specifications :

EN 61000-6-4:2007 EMC Generic Emission Standard for the Industrial Environments

EN 61000-6-2:2005 EMC Generic Immunity Standard for the Industrial Environments

EN 61010-1:2001 Safety Requirements for electrical equipment for measurement, control And laboratory use

When and Where Issued

16th October 2009

Bursa-TURKEY

Authorized Signature

Name : Serpil YAKIN

Position : Quality Manager

1. Preface

ESM series process indicators are designed for measuring temperature and any process value. They can be used in many applications with their universal process input, alarm functions and serial communication unit.

Some application fields which they are used are below:

Application Fields

Glass
Plastic
Petro-Chemistry
Textile
Automotive
Machine production industries

1.1 General Specifications

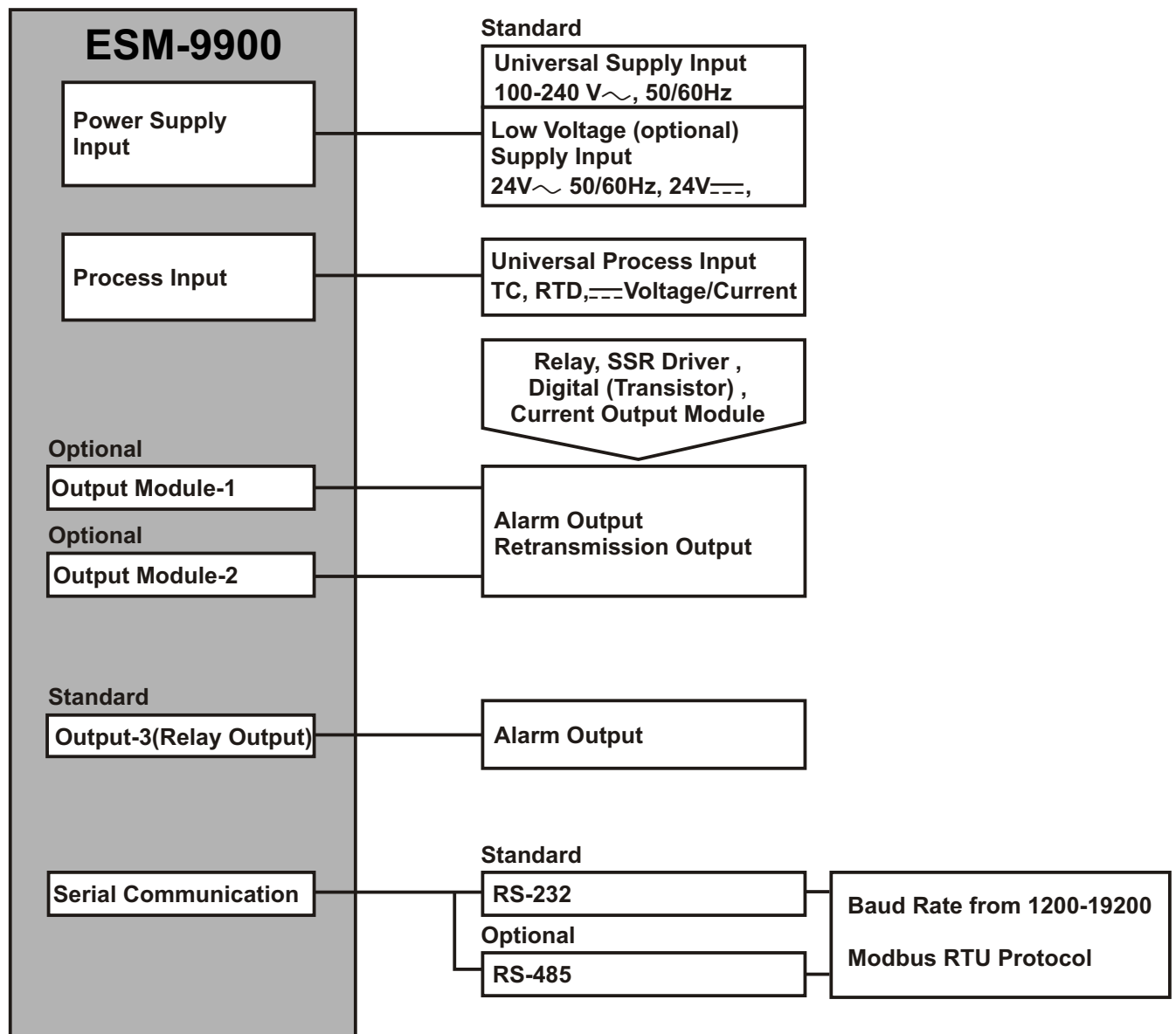

1.2 Ordering Information

ESM-9900 (96x96 1/4 DIN)	A	BC	D	E	/	FG	HI	/	U	V	W	Z
				1	/			/				

A	Supply Voltage
1	100-240V \sim (-15%;+10%) 50/60Hz
2	24 V \sim (-15%;+10%) 50/60Hz 24V \equiv (-15%;+10%)
9	Customer (Maximum 240V \sim (-15%;+10%) 50/60Hz

BC	Input Type	Scale
20	Configurable(Table-1)	Table-1

D	Serial Communication	Product Code
0	None	-
1	RS-232	EMC-900
2	RS-485	EMC-910

E	Output-1
1	Relay Output

FG	Module-1	Product Code
00	None	-
01	Relay Output Module	EMO-900
02	SSR Driver Output Module	EMO-910
03	Digital (Transistor) Output Module	EMO-920
04	Current Output Module (0/4 ...20 mA \equiv)	EMO-930

HI	Module-2	Product Code
00	None	-
01	Relay Output Module	EMO-900
02	SSR Driver Output Module	EMO-910
03	Digital (Transistor) Output Module	EMO-920
04	Current Output Module (0/4 ...20 mA \equiv)	EMO-930

All order information of ESM-9900 are given on the table at left. User may form appropriate device configuration from information and codes that at the table and convert it to the ordering codes.

Firstly, supply voltage then output modules and other specifications must be determined. Please fill the order code blanks according to your needs.

Please contact us, if your needs are out of the standards.



\sim Symbol means Vac,

\equiv Symbol means Vdc

\sim Symbol means Vac and Vdc

Table-1

BC	Input Type(TC)	Scale(°C)	Scale(°F)
21	L ,Fe Const DIN43710	-100°C,850°C	-148°F,1562°F
22	L ,Fe Const DIN43710	-100.0°C,850.0°C	-148.0°F,999.9°F
23	J ,Fe CuNi IEC584.1(ITS90)	-200°C,900°C	-328°F,1652°F
24	J ,Fe CuNi IEC584.1(ITS90)	-199.9°C,900.0°C	-199.9°F,999.9°F
25	K ,NiCr Ni IEC584.1(ITS90)	-200°C,1300°C	-328°F,2372°F
26	K ,NiCr Ni IEC584.1(ITS90)	-199.9°C,999.9°C	-199.9°F,999.9°F
27	R ,Pt13%Rh Pt IEC584.1(ITS90)	0°C,1700°C	32°F,3092°F
28	R ,Pt13%Rh Pt IEC584.1(ITS90)	0.0°C,999.9°C	32.0°F,999.9°F
27	S ,Pt10%Rh Pt IEC584.1(ITS90)	0°C,1700°C	32°F,3092°F
28	S ,Pt10%Rh Pt IEC584.1(ITS90)	0.0°C,999.9°C	32.0°F,999.9°F
29	T ,Cu CuNi IEC584.1(ITS90)	-200°C,400°C	-328°F,752°F
30	T ,Cu CuNi IEC584.1(ITS90)	-199.9°C,400.0°C	-199.9°F,752.0°F
31	B ,Pt30%Rh Pt6%Rh IEC584.1(ITS90)	44°C,1800°C	111°F,3272°F
32	B ,Pt30%Rh Pt6%Rh IEC584.1(ITS90)	44.0°C,999.9°C	111.0°F,999.9°F
33	E ,NiCr CuNi IEC584.1(ITS90)	-150°C,700°C	-238°F,1292°F
34	E ,NiCr CuNi IEC584.1(ITS90)	-150.0°C,700.0°C	-199.9°F,999.9°F
35	N ,Nicrosil Nisil IEC584.1(ITS90)	-200°C,1300°C	-328°F,2372°F
36	N ,Nicrosil Nisil IEC584.1(ITS90)	-199.9°C,999.9°C	-199.9°F,999.9°F
37	C , (ITS90)	0°C,2300°C	32°F,3261°F
38	C , (ITS90)	0.0°C,999.9°C	32.0°F,999.9°F

BC	Input Type(RTD)	Scale(°C)	Scale(°F)
39	PT 100 , IEC751(ITS90)	-200°C,650°C	-328°F,1202°F
40	PT 100 , IEC751(ITS90)	-199.9°C,650.0°C	-199.9°F,999.9°F

BC	Input Type (\equiv Voltage and Current)	Scale
41	0...50 mV \equiv	-1999 9999
42	0...5 V \equiv	-1999 9999
43	0...10 V \equiv	-1999 9999
44	0...20 mA \equiv	-1999 9999
45	4...20 mA \equiv	-1999 9999

1.3 Warranty

EMKO Elektronik warrants that the equipment delivered is free from defects in material and workmanship. This warranty is provided for a period of two years. The warranty period starts from the delivery date. This warranty is in force if duty and responsibilities which are determined in warranty document and instruction manual performs by the customer completely.

1.4 Maintenance

Repairs should only be performed by trained and specialized personnel. Cut power to the device before accessing internal parts.

Do not clean the case with hydrocarbon-based solvents (Petrol, Trichlorethylene etc.). Use of these solvents can reduce the mechanical reliability of the device. Use a cloth dampened in ethyl alcohol or water to clean the external plastic case.

2. Installation



Before beginning installation of this product, please read the instruction manual and warnings below carefully.

In package ,

- One piece unit
- Two pieces mounting clamps
- One piece instruction manual

A visual inspection of this product for possible damage occurred during shipment is recommended before installation. It is your responsibility to ensure that qualified mechanical and electrical technicians install this product.

If there is danger of serious accident resulting from a failure or defect in this unit, power off the system and separate the electrical connection of the device from the system.

The unit is normally supplied without a power switch or a fuse. Use power switch and fuse as required.

Be sure to use the rated power supply voltage to protect the unit against damage and to prevent failure.

Keep the power off until all of the wiring is completed so that electric shock and trouble with the unit can be prevented.

Never attempt to disassemble, modify or repair this unit. Tampering with the unit may results in malfunction, electric shock or fire.

Do not use the unit in combustible or explosive gaseous atmospheres.

During the equipment is putted in hole on the metal panel while mechanical installation some metal burrs can cause injury on hands, you must be careful.

Montage of the product on a system must be done with it's mounting clamp. Do not do the montage of the device with inappropriate mounting clamp. Be sure that device will not fall while doing the montage.

It is your responsibility if this equipment is used in a manner not specified in this instruction manual.

2.1 General Description

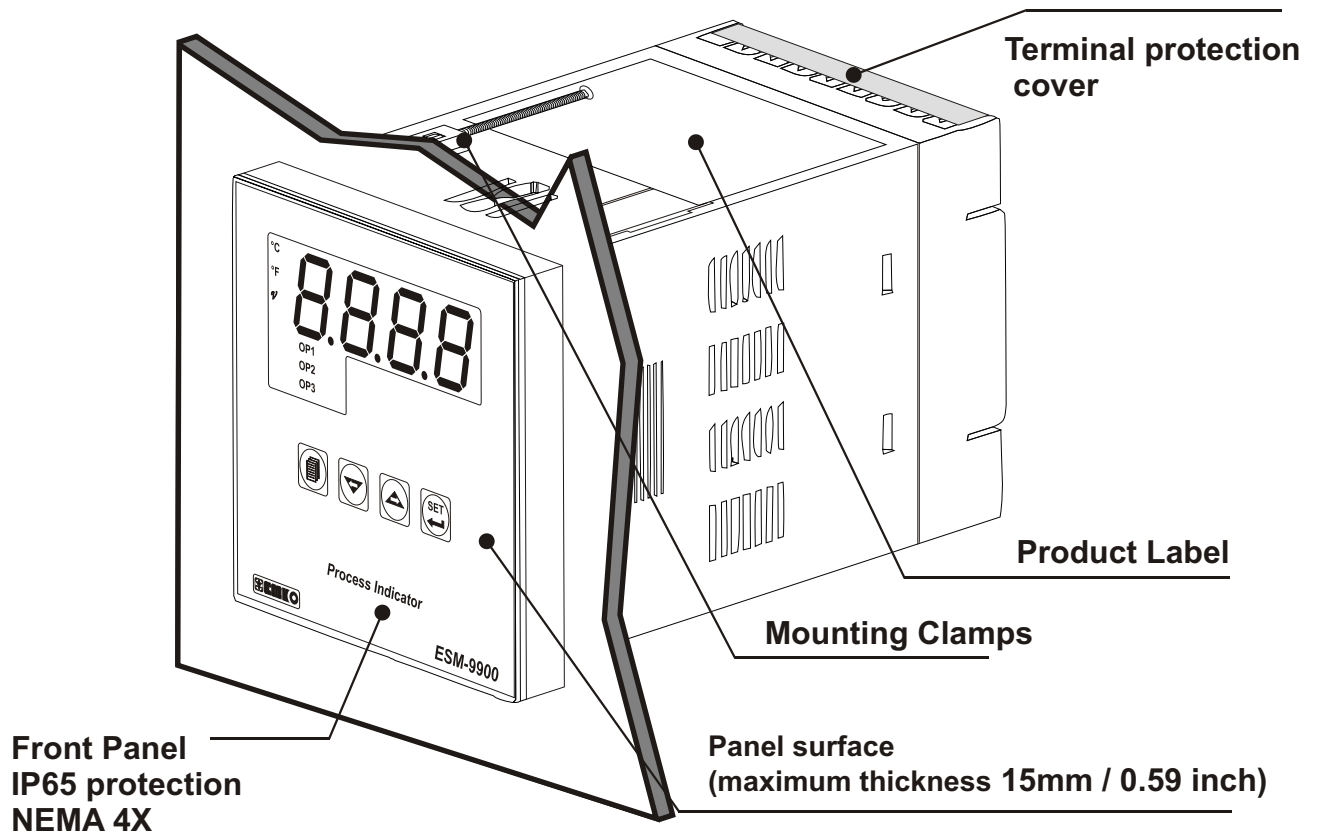

2.2 Dimensions

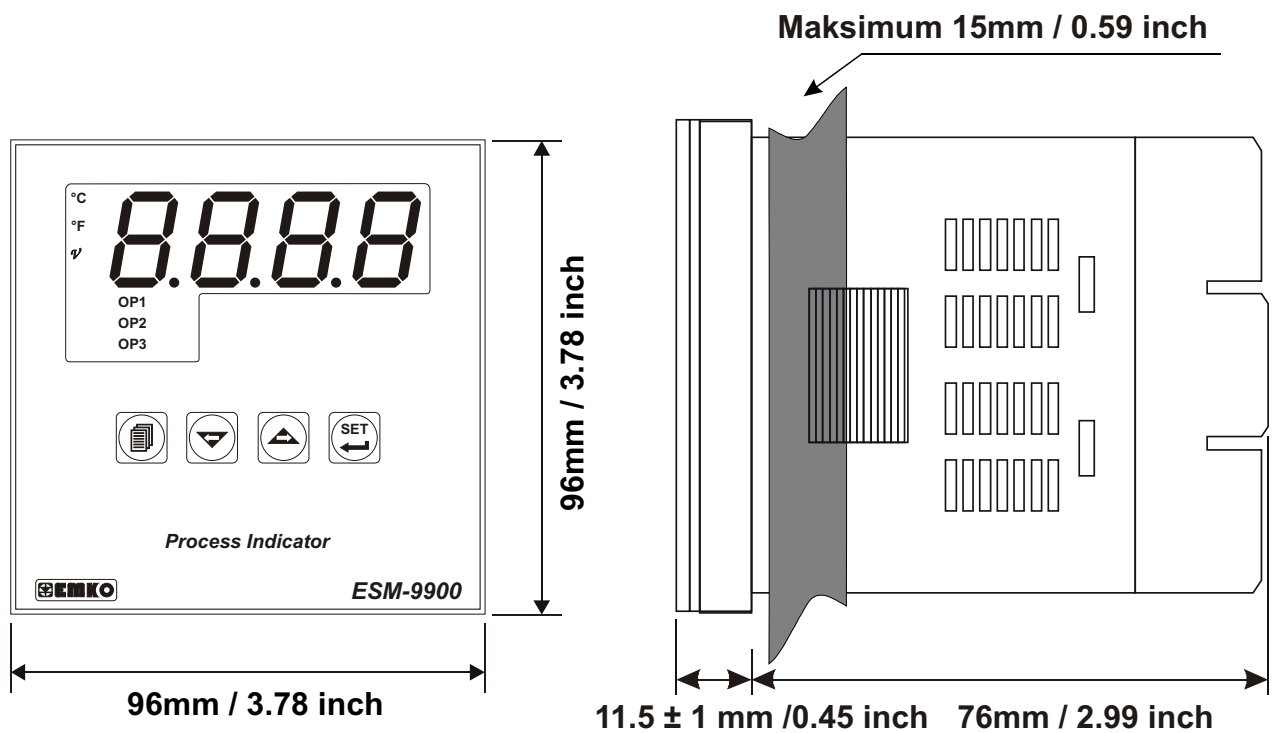

2.3 Panel Cut-Out

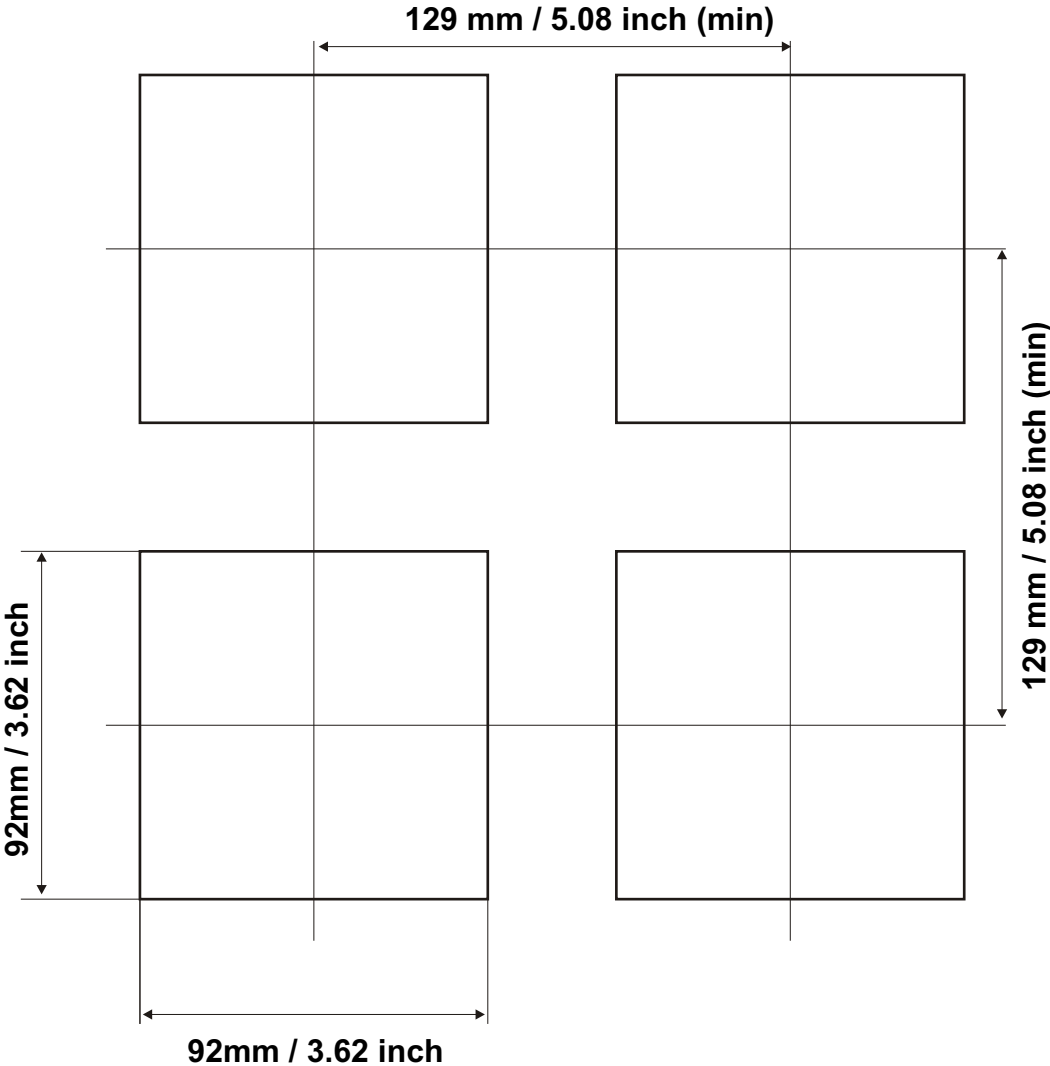

2.4 Environmental Ratings

Operating Conditions



Operating Temperature : 0 to 50 °C



Max. Operating Humidity : 90% Rh (non-condensing)



Altitude : Up to 2000m.



Forbidden Conditions:

Corrosive atmosphere

Explosive atmosphere

Home applications (The unit is only for industrial applications)

2.5 Panel Mounting

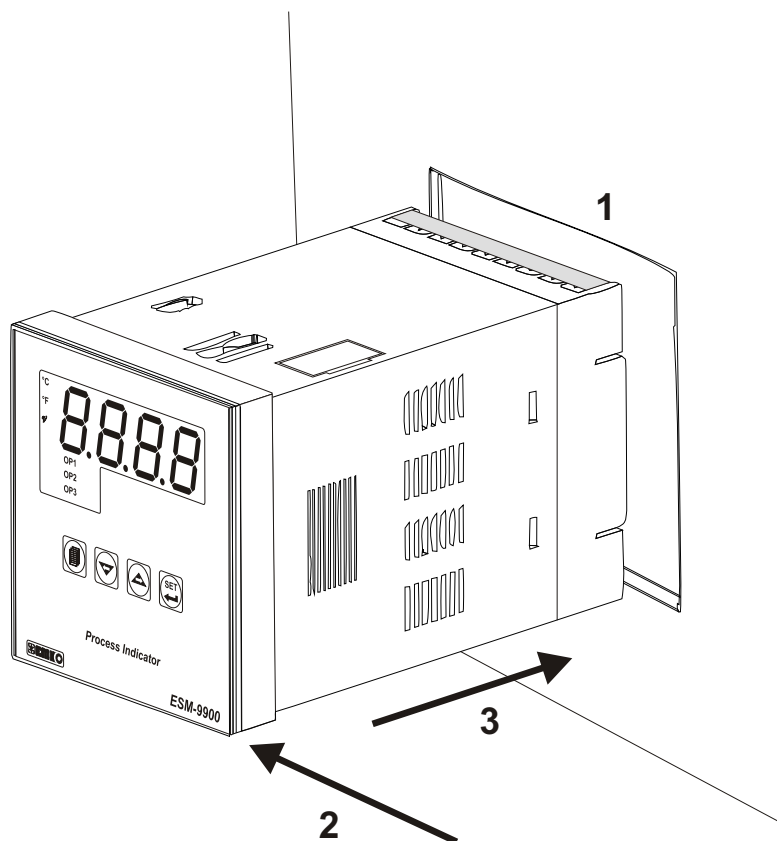

1-Before mounting the device in your panel, make sure that the cut-out is of the right size.

2-Check front panel gasket position

3-Insert the device through the cut-out. If the mounting clamps are on the unit, put out them before inserting the unit to the panel.



During installation into a metal panel, care should be taken to avoid injury from metal burrs which might be present. The equipment can loosen from vibration and become dislodged if installation parts are not properly tightened. These precautions for the safety of the person who does the panel mounting.

2.6 Installation Fixing Clamp

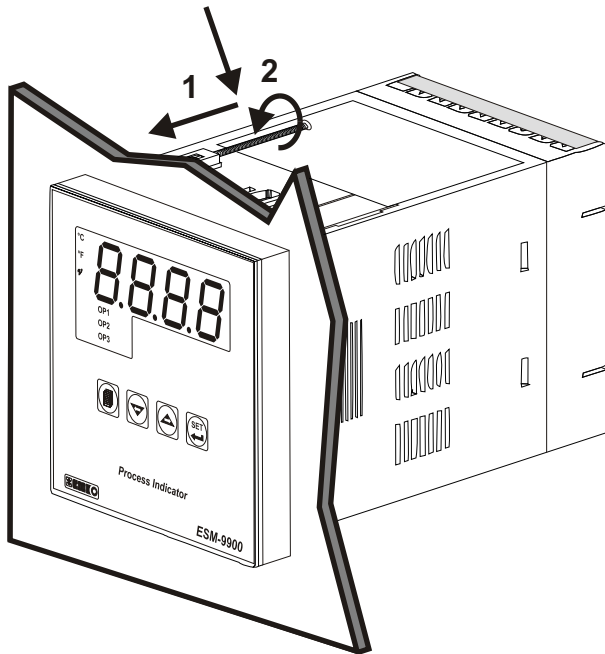

The unit is designed for panel mounting.

1-Insert the unit in the panel cut-out from the front side.

2- Insert the mounting clamps to the holes that located top and bottom sides of device and screw up the fixing screws until the unit completely immobile within the panel



Montage of the unit to a system must be done with it's own fixing clamps. Do not do the montage of the device with inappropriate fixing clamps. Be sure that device will not fall while doing the montage.

2.7 Removing from the Panel



Before starting to remove the unit from panel, power off the unit and the related system.

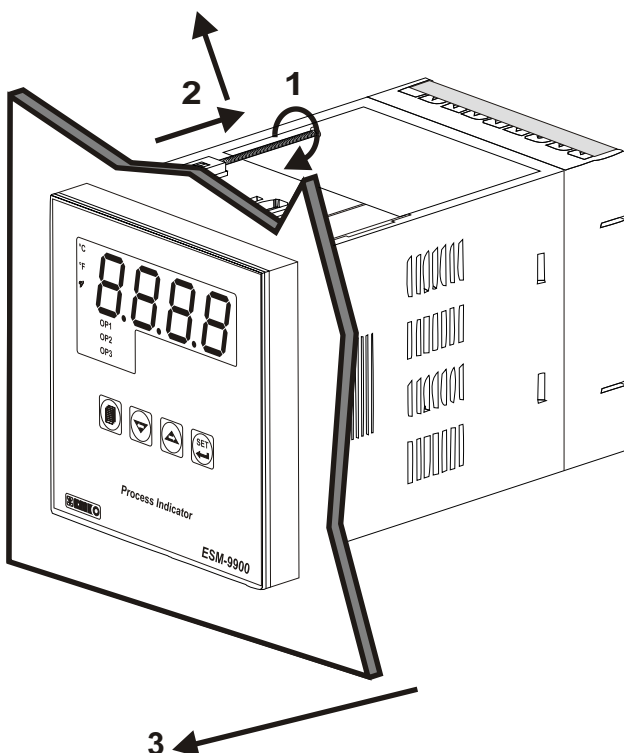

1-Loosen the screws.

2-Pull mounting clamps from top and bottom fixing sockets.

3-Pull the unit through the front side of the panel

3. Electrical Wirings



You must ensure that the device is correctly configured for your application. Incorrect configuration could result in damage to the process being controlled, and/or personal injury. It is your responsibility, as the installer, to ensure that the configuration is correct.

Parameters of the device has factory default values. These parameters must be set according to the system's needs.



Only qualified personnel and technicians should work on this equipment. This equipment contains internal circuits with voltage dangerous to human life. There is severe danger for human life in the case of unauthorized intervention.



Be sure to use the rated power supply voltage to protect the unit against damage and to prevent failure.



Keep the power off until all of the wiring is completed so that electric shock and trouble with the unit can be prevented.

3.1 Terminal Layout and Connection Instructions

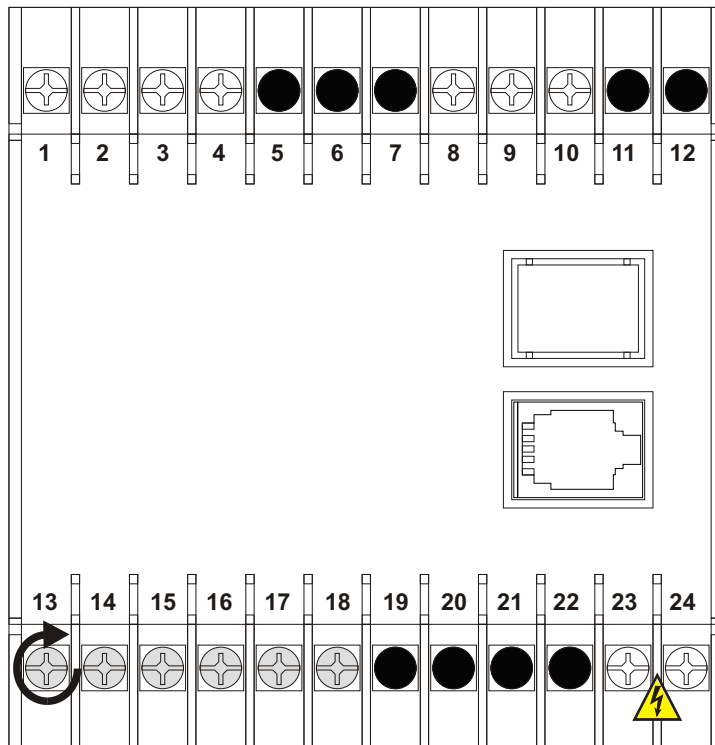

0.5Nm

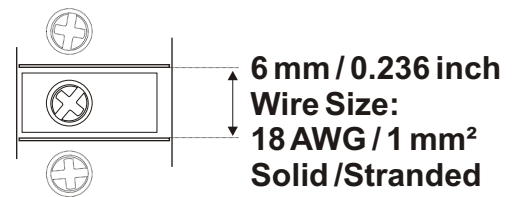

24 screws
terminal M3



Optional
Connections



Empty terminals



Torque 0.5 Nm



Screw driver
0.8x3mm

3.2 Electrical Wiring Diagram



Electrical wiring of the device must be the same as 'Electrical Wiring Diagram' below to prevent damage to the process being controlled and personnel injury.

Universal Process Input
(TC, RTD, --- Voltage/Current)

Sensor or Transmitter Supply Voltage

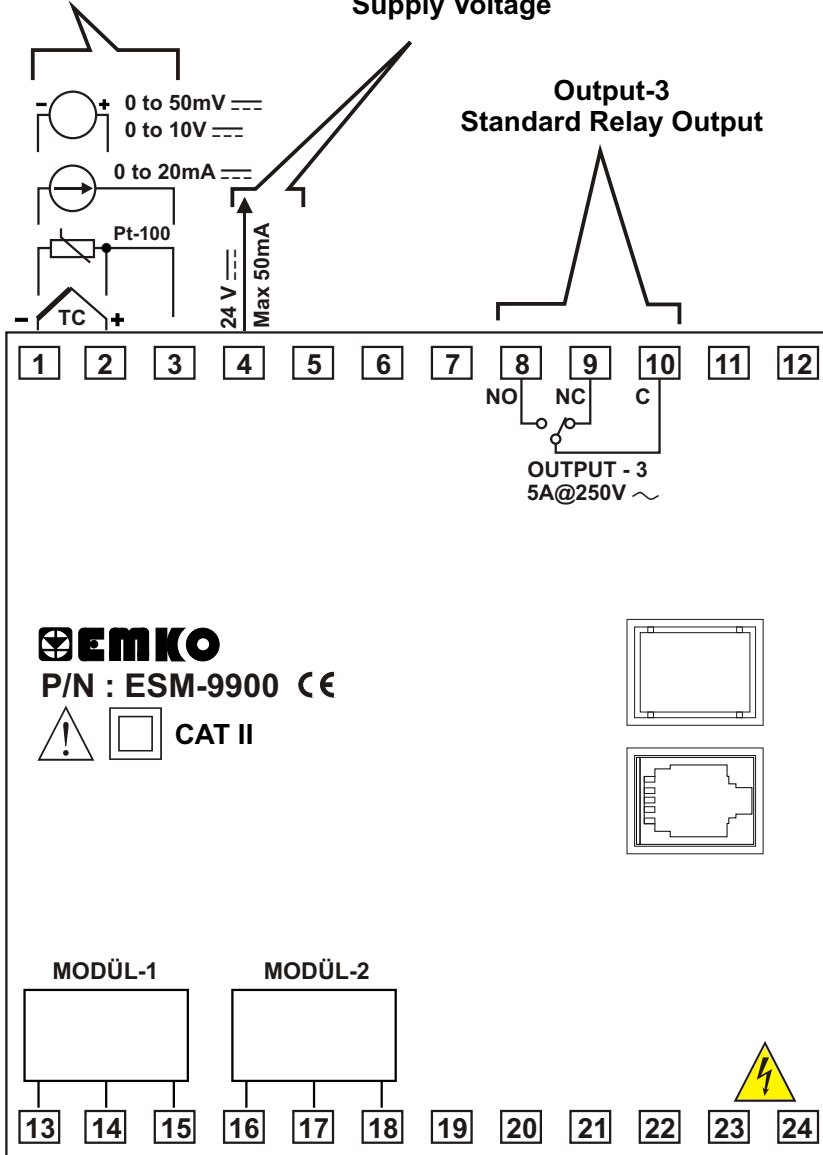

Output-3
Standard Relay Output

EMKO
P/N : ESM-9900 CE
CAT II

Communication Socket

Optional Output Module Terminals
Relay, SSR Driver, Digital or Current Output Module

Supply Voltage Input
100-240V \sim (-15%;+10%) 50/60Hz - 6VA
24 V \sim (-15%;+10%) 50/60Hz - 6VA
24V --- (-15%;+10%) - 6W
(It must be determined in order)



Process input is in CAT II class.

3.3 Supply Voltage Input Connection of the Device

Connection of Universal Supply Voltage Input

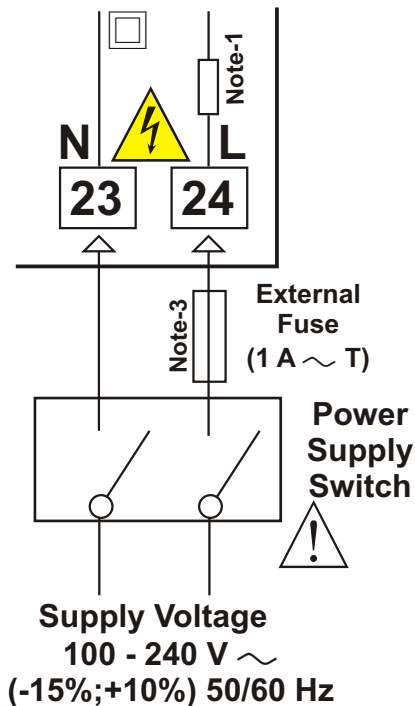

Connection of Low Voltage 24 V \sim Supply Voltage Input

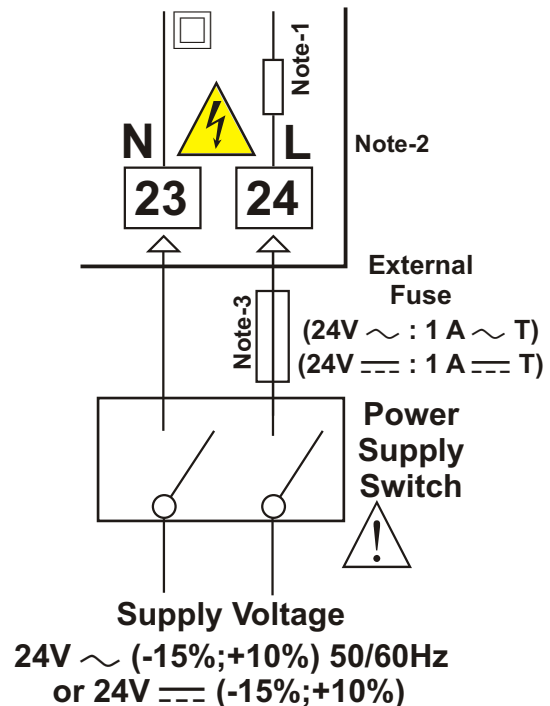

Note-1 : There is an internal 33R fusible flameproof resistor in 100-240 V \sim 50/60Hz supply voltage input

There is an internal 4R7 fusible flameproof resistor in 24V \sim 50/60Hz , 24V=== supply voltage input

Note-2 : "L" is (+) , "N" is (-) for 24V=== supply voltage

Note-3 : External fuse is recommended.



Make sure that the power supply voltage is the same indicated on the instrument.

Switch on the power supply only after that all the electrical connections have been completed.

Supply voltage range must be determined in order. While installing the unit, supply voltage range must be controlled and appropriate supply voltage must be applied to the unit. Controlling prevents damages in unit and system and possible accidents as a result of incorrect supply voltage.



There is no power supply switch on the device. So a power supply switch must be added to the supply voltage input. In accordance with the safety regulations, the power supply switch shall bring the identification of the relevant instrument. Power supply switch shall be easily accessible by the user.

Power switch must be two poled for separating phase and neutral. On/Off condition of power switch is very important in electrical connection. On/Off condition of power switch must be signed for preventing the wrong connection.

If an external fuse is used, it must be on phase connection in \sim supply input.

If an external fuse is used, it must be on (+) line connection in === supply input.



The instrument is protected with an internal fuse (Please refer to Note1 for information). In case of failure it is suggested to return the instrument to the manufacturer for repair.

3.4 Process Input Connection

3.4.1 TC (Thermocouple) Connection

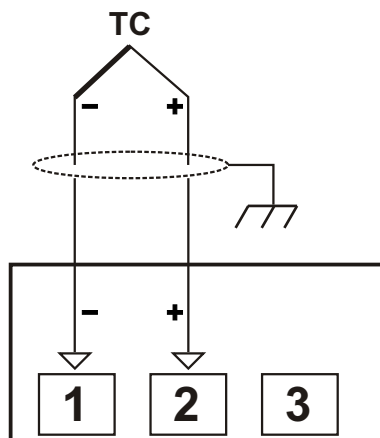

Connect the wires with the polarity as shown in the figure left.

- i** Always use compensation wire corresponding to the thermocouple used. If present, the shield must be connected to a proper ground.
- i** Input resistance is greater than 10M

3.4.2 RTD Connection

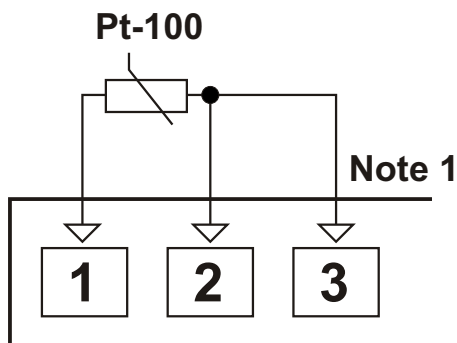

3-wire Pt-100 connection
(with line compensation)
(Max. Line impedance is 10)

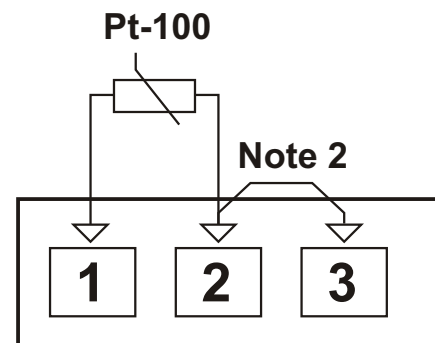

2-wire Pt-100 connection
(without line compensation)

Note 1 : In 3-wire system, use always cables of the same diameter (min 1mm²) Always use wires of the same gauge and type whether a 2-wire or 3-wire system.

Note 2 : Install a jumper between terminals 2 and 3 when using a 2-wire RTD.

Note 3 : If the distance is longer than 10 meters, use 3-wire system

- i** Input resistance is greater than 10M

3.4.3 Process Input Connection of Serial Transmitters with Current Output (Loop Powered)

Transmitter connection by using supply voltage on the device

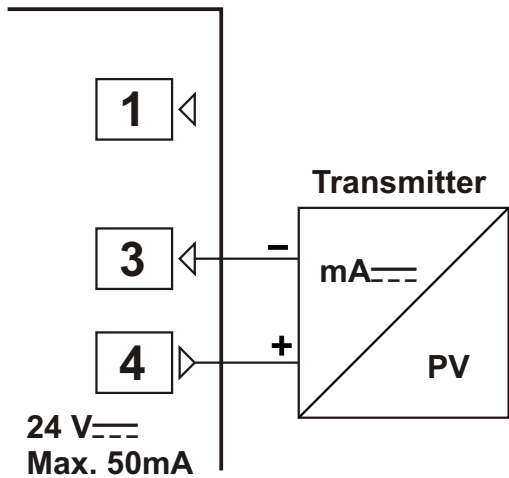

Transmitter connection by using external supply voltage source.

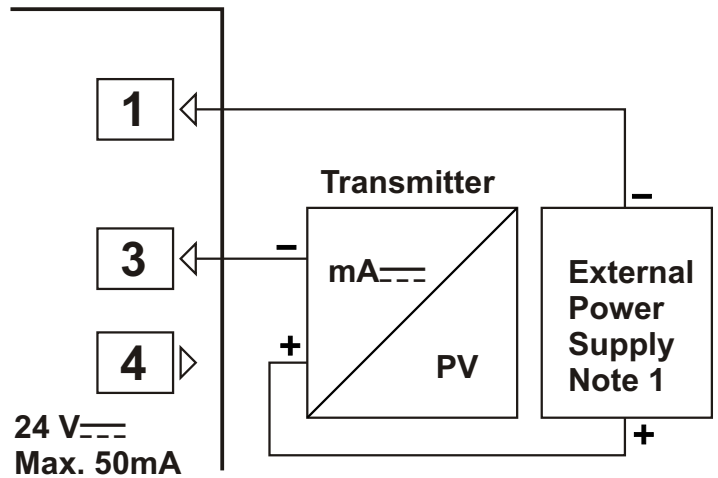

Note 1 : External power supply must be selected according to supply voltage range and required current for transmitter.



Input Resistance is $2R7$.

3.4.4 Process Input Connection of 3-Wire Transmitters with Current Output

Transmitter connection by using supply voltage on the device

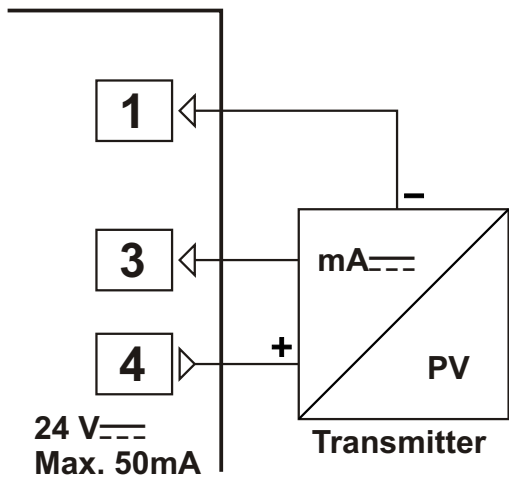

Transmitter connection by using external supply voltage source.

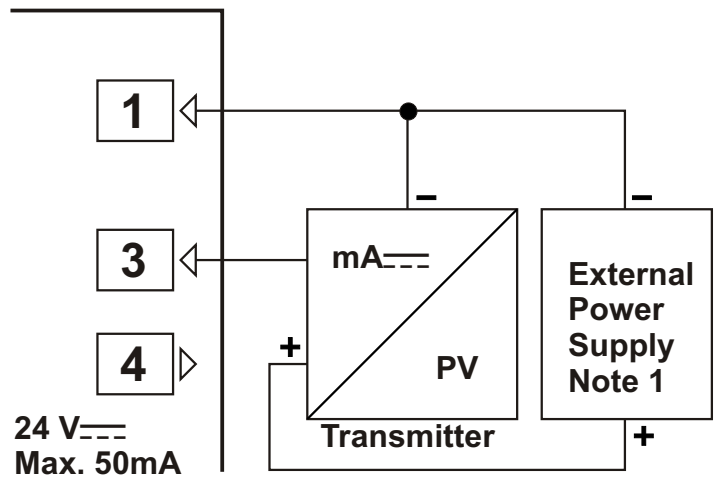

Note 1 : External power supply must be selected according to supply voltage range and required current for transmitter.



Input Resistance is $2R7$.

3.4.5 Connection of Transmitters with Voltage Output to Process Input

Transmitter connection by using supply voltage on the device

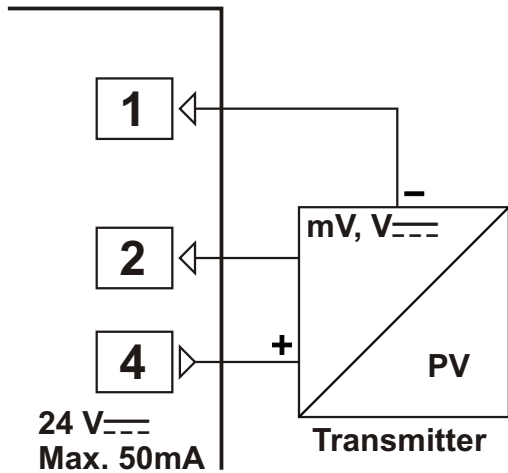

Transmitter connection by using external supply voltage source.

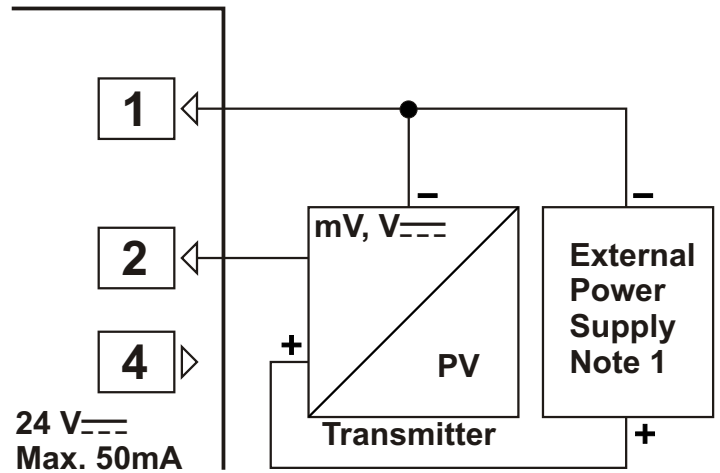

Note 1 : External power supply must be selected according to supply voltage range and required current for transmitter.



Input resistance is greater than 10M for 0...50mV
 Input resistance is 43K for 0...10V

3.5 Relay Output Connection

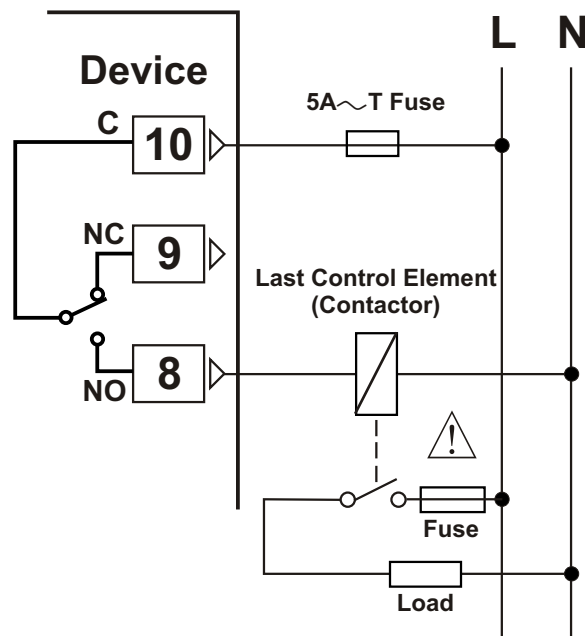

Fuses must be selected according to the application.

3.6 Galvanic Isolation Test Values of ESM-9900 Process Indicator and Output Modules

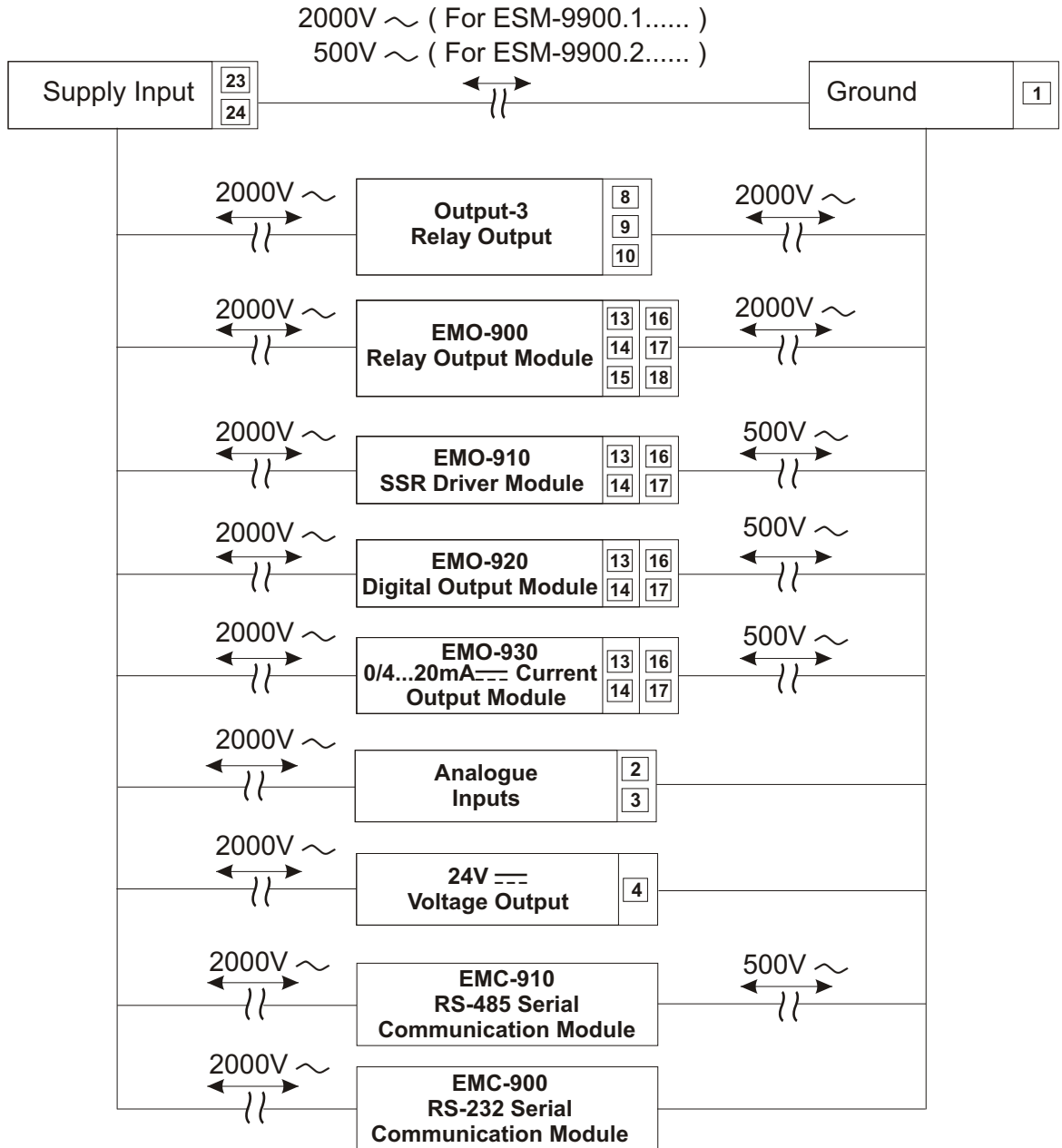

4. Definitions and Specifications of Modules

ESM-9900 Process Indicator is a modular product which is designed to operate with additional analogue and digital output units which user may need.

Two output modules can be plugged in the device by the user. User may configure the product for different applications according to the system requirements with the output modules which are described in this section.

4.1 Output Modules

Dimensions of Output Modules

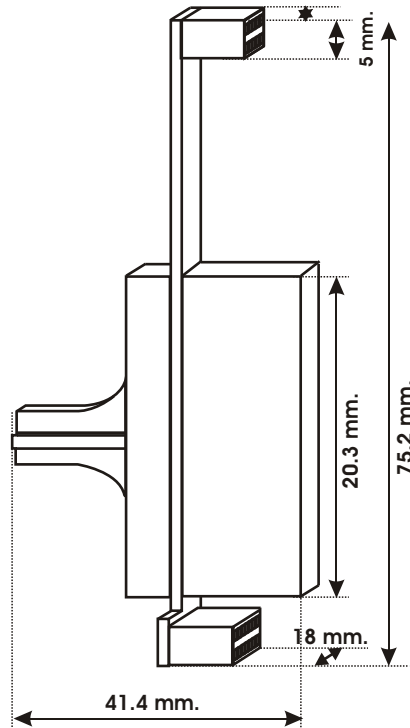

4.1.1 EMO-900 Relay Output Module

EMO-900 Relay output module can be plugged in Module-1 or Module-2 socket to use functions which are defined for relay output.

Specifications of EMO-900 Relay Output Module

Output : 5A @ 250V~, Open / Close Contact
Dimensions : 18x75.2x41.4mm
Electrical Life : 100.000 Operation (Full Load)

Applications of EMO-900 Relay Output Module

It can be used with heating or cooling functions as process control output, as alarm output by programmable different alarm functions, as logic output to transfer some datas on the device to the system. These alternatives are explained in parameters section as logic output function.



Detailed information about functions of EMO-900 Relay Output Module are given in parameters section. For using these functions EMO-900 Relay Output Module must be installed to Module-1 or Module-2 socket.

4.1.2 EMO-910 SSR Driver Output Module

EMO-910 SSR Driver Output Module can be plugged in Module-1 or Module-2 socket to use functions which are defined for SSR driver output.

Specifications of EMO-910 SSR Driver Module

Output : Maximum 26 mA, Max. 22V $\overline{=}$ $\pm 10\%$, isolated

Dimensions : 18x75.2x41.4mm

Applications of EMO-910 SSR Driver Output Module

It can be used with heating or cooling functions as process control output, as alarm output by programmable different alarm functions, as logic output to transfer some data on the device to the system.

Note 1 : If short output period is needed in a system, using SSR Driver output module is recommended. (Relay must not be used for short output periods because of limited life of their relay contact (open/close events))



Detailed information about functions of EMO-910 SSR Driver Output Module are given in parameters section. For using these functions EMO-910 SSR Driver Output Module must be installed to Module-1 or Module-2 socket.

4.1.3 EMO-920 Digital (Transistor) Output Module

EMO-920 Digital (Transistor) Output Module can be plugged in Module-1 or Module-2 socket to use functions which are defined for digital output.

Specifications of EMO-920 Digital (Transistor) Output Module

Output : Maximum 40 mA, 15-18V $\overline{=}$ $\pm 10\%$, isolated

Dimensions : 18x75.2x41.4mm

Applications of EMO-920 Digital (Transistor) Output Module

It can be used with heating or cooling functions as process control output, as alarm output by programmable different alarm functions, as logic output to transfer some data on the device to the system. These alternatives are explained in parameters section as logic output function.



Detailed information about functions of EMO-920 Digital (Transistor) Output Module are given in parameters section. For using these functions EMO-920 Digital (Transistor) Output Module must be installed to Module-1 or Module-2 socket.

4.1.4 EMO-930 0 / 4 ...20mA_{rms} Current Output Module

EMO-930 0/4...20mA_{rms} Current Output Module can be plugged in Module-1 or Module-2 socket to use functions which are defined for current or voltage output. (It is defined as Analogue Output Module in some sections)

Specifications of EMO-930 0/4...20mA_{rms} Current Output Module

Output : 0/4...20mA_{rms} current output

Accuracy : 1%

Note : To get 0...10V_{rms} , 500 Ω resistor with 0.05% tolerance must be connected in parallel as a shunt resistor to module output (Please refer to Section 5.1.5 for detailed information)

Maximum load impedance : 600

Dimensions : 18x75.2x41.4mm

Applications of EMO-930 0/4...20mA_{rms} Current Output Module

It can be used in heating or cooling functions as process control output.

Process value, difference between process and set value or set value can be retransmitted to the system as 0...20mA_{rms} or 4...20mA_{rms} output. Retransmission is explained in parameters section.



Detailed information about functions of EMO-930 Current Output Module are given in parameters section. For using these functions EMO-930 0/4...20mA_{rms} current Output Module must be installed to Module-1 or Module-2 socket.

4.2 Installing and Pulling Out Input/Output Modules



First, detach all cable connections from the device and uninstall it from the panel.

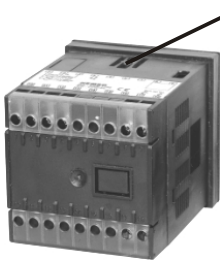

Suppress to the lock pins where top and bottom of the device

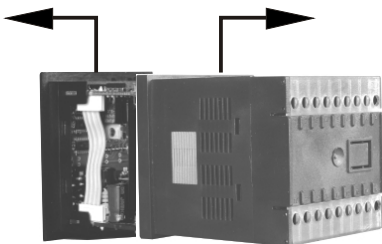

Pull the cover case with your other hand from front panel to rear side.

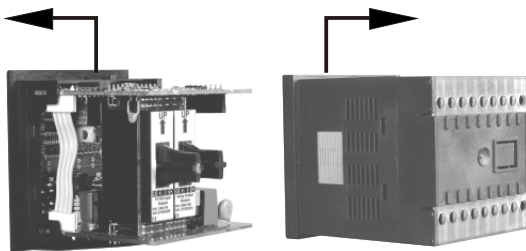

Pull out the cover case from the device

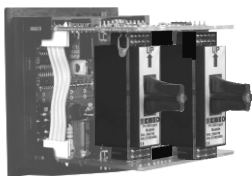

Slide input/output modules into socket.

Pull out the module from it's socket, instead of this module install the new one or other module user wants to use.

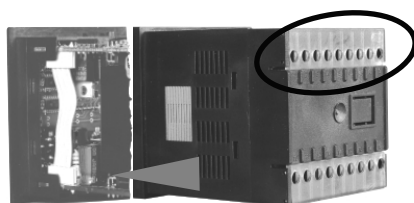

Replace the cover case by taking care of the terminal numbers should be at right position.



After adding or changing modules to the unit, these changes must be taken into consideration while mounting of the unit to the system. If mounting is incorrect, it can cause accidents to harm system, operator or person who does the mounting. Responsibility of these kind of harmful events belongs to the user.

4.3 To Stick Output Modules' Labels to the Device

Every module which is plugged in Module-1 or Module-2 socket has labels' for showing the relation between connection terminal and the device. These labels are attached to empty boxes which are separated for Module-1 and Module-2 on the device. Labels for all modules and attachment places are shown below.

Label which describes terminal connection of module that is plugged in Module-2 socket is attached to this area.

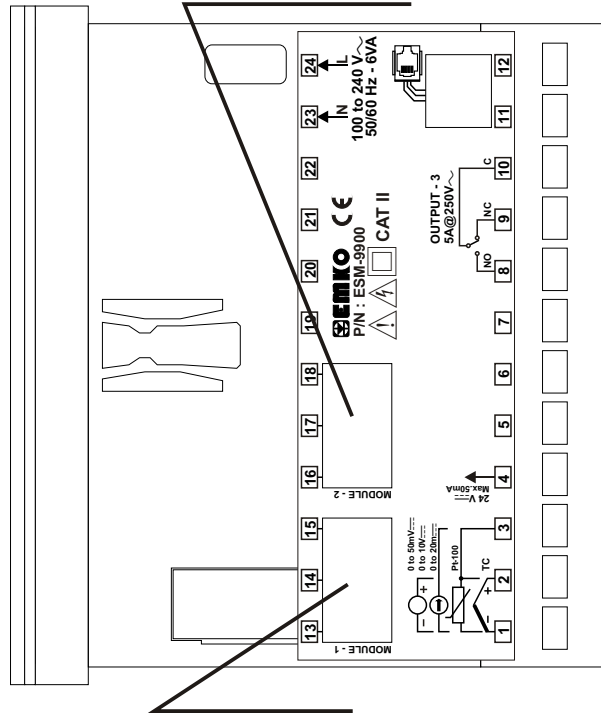

Label which describes terminal connection of module that is plugged in Module-1 socket is attached to this area.

LABELS FOR OUTPUT MODULES

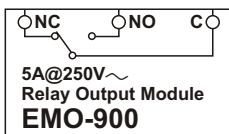

Label for EMO-900 Relay Output Module

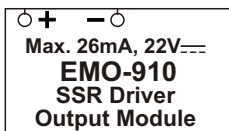

Label for EMO-910 SSR Driver Output Module

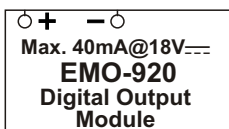

Label for EMO-920 Digital Output Module

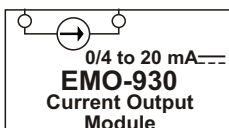

Label for EMO-930 0/4...20mA DC Current Output Module

Example : If user installs EMO-900 Relay Output Module to Module-1 socket, EMO-930 0/4...20mA $\overline{\text{=}}$ Current Output Module to Module-2 socket and attach the appropriate labels on the device view will be like below :

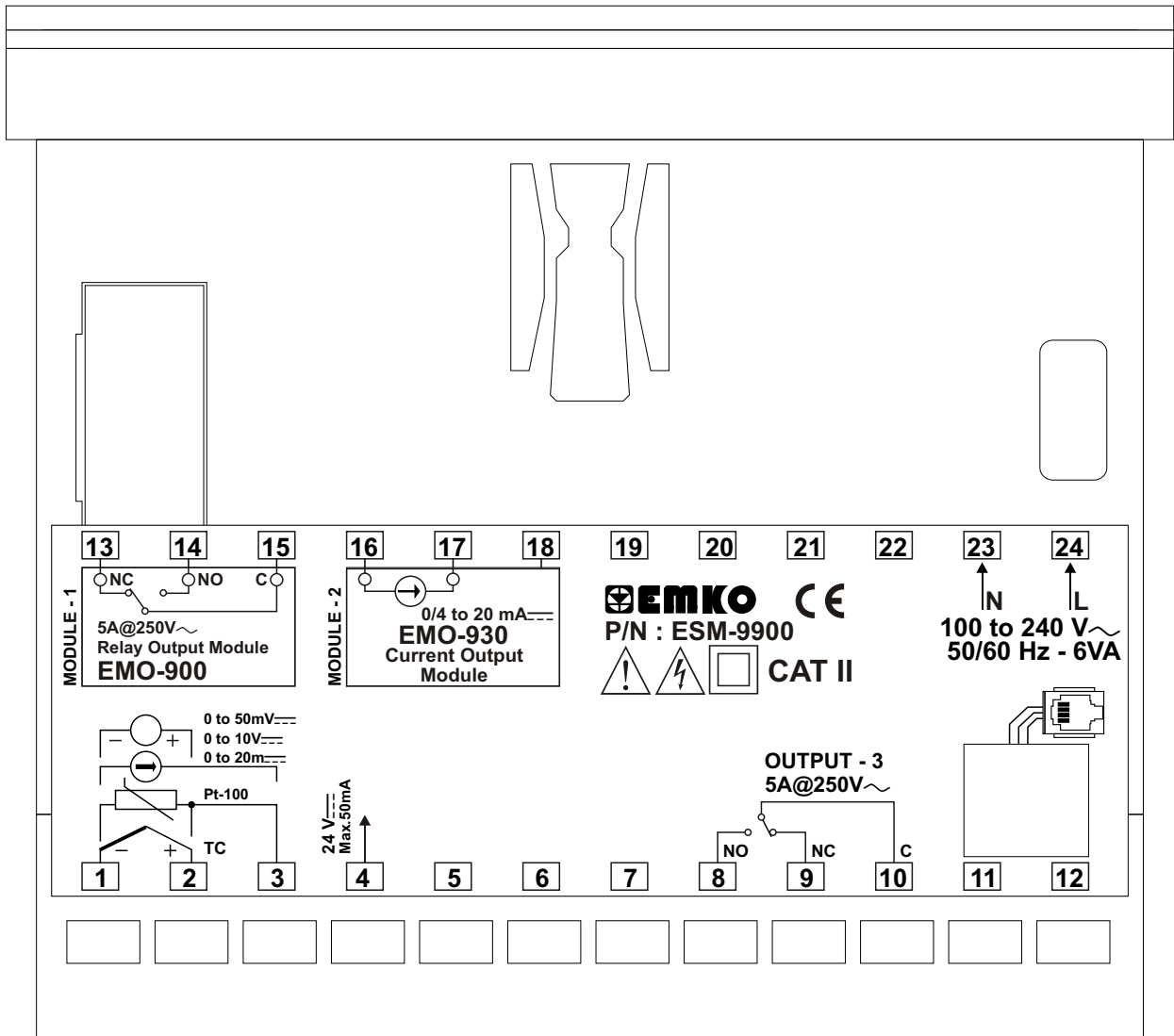

5. Connection Terminals of Output Modules and Connection Wirings

Module-1 / Module-2 Optional Output Modules

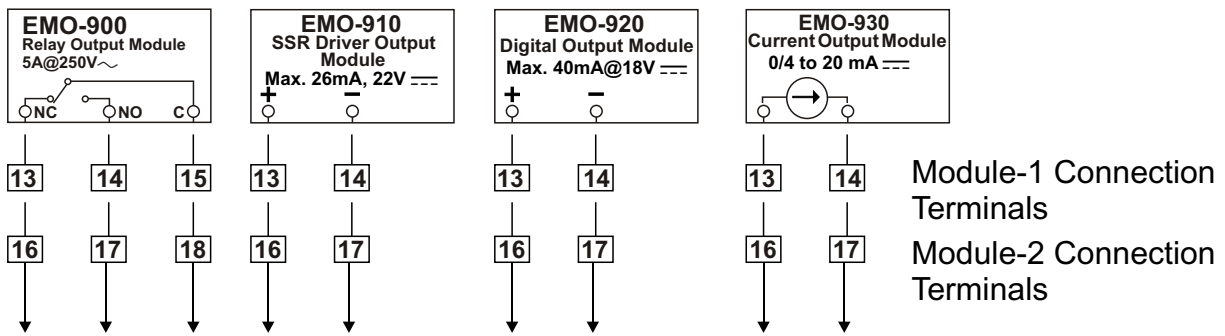

5.1 Connection Wirings for Output Modules

5.1.1 EMO-900 Relay Output Module Connection

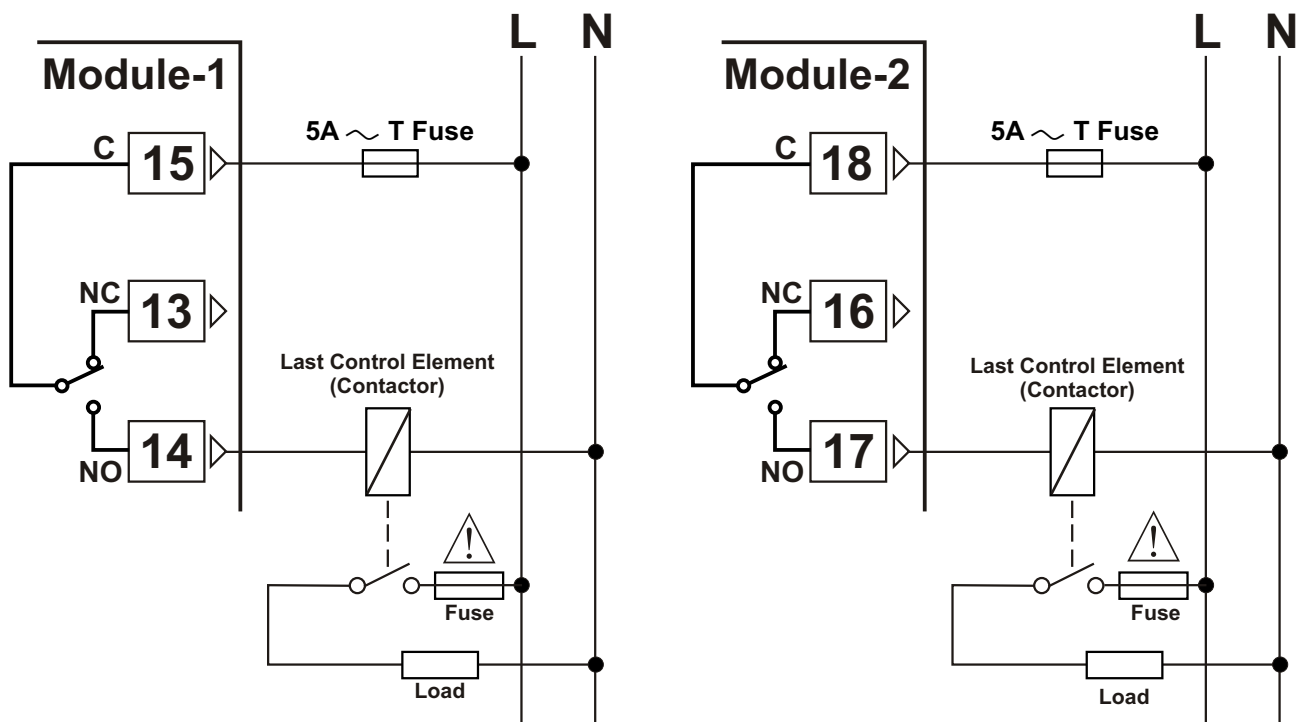

Fuses must be selected according to the applications.

5.1.2 EMO-910 SSR Driver Module Connection

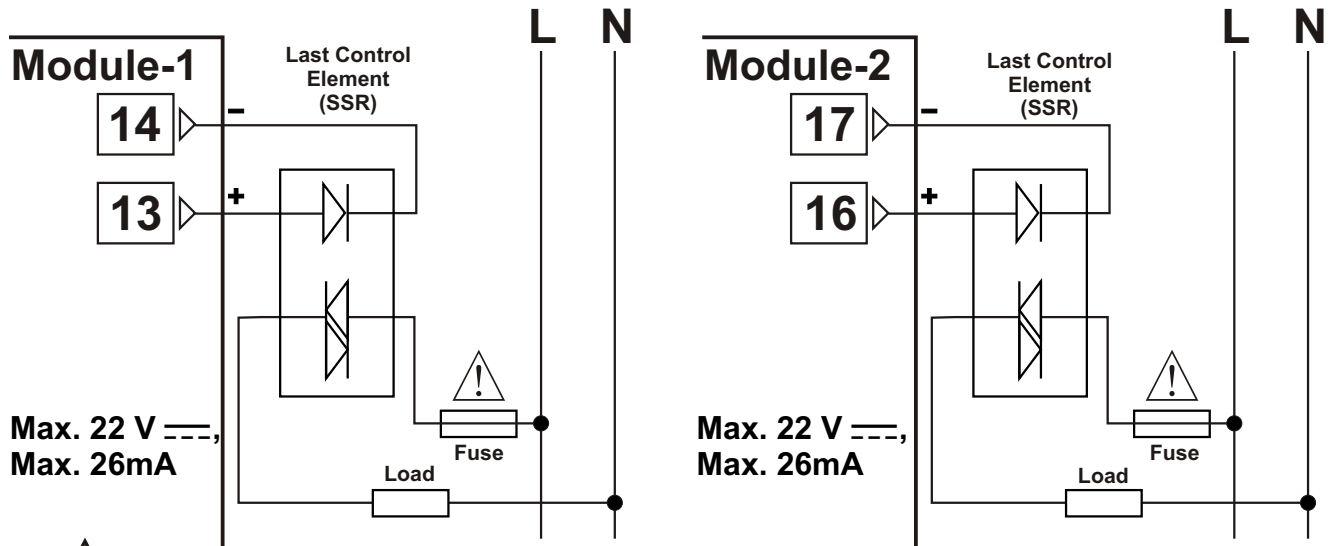

Fuses must be selected according to the applications.

5.1.3 EMO-920 Digital (Transistor) Output Module Connection



5.1.4 EMO-930 0/4... 20 mA Current Output Module Connection

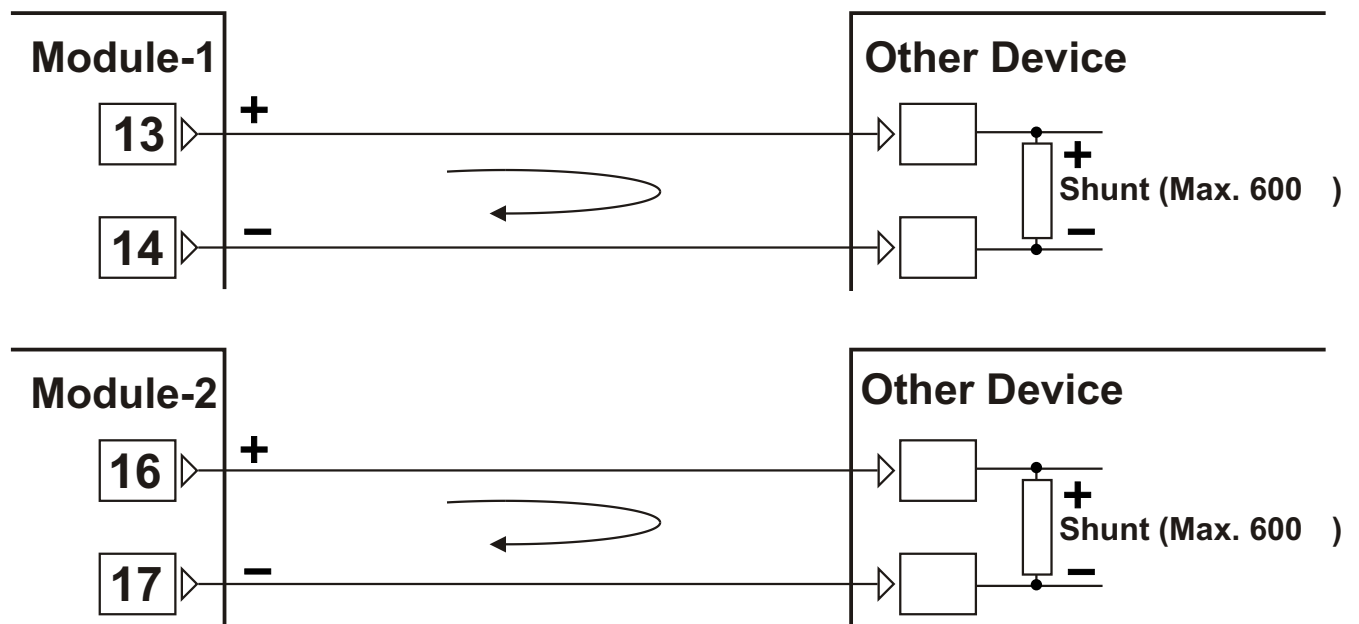

5.1.5 To Get 0...10V_{DC} with EMO-930 0/4...20 mA_{DC} Current Output Module

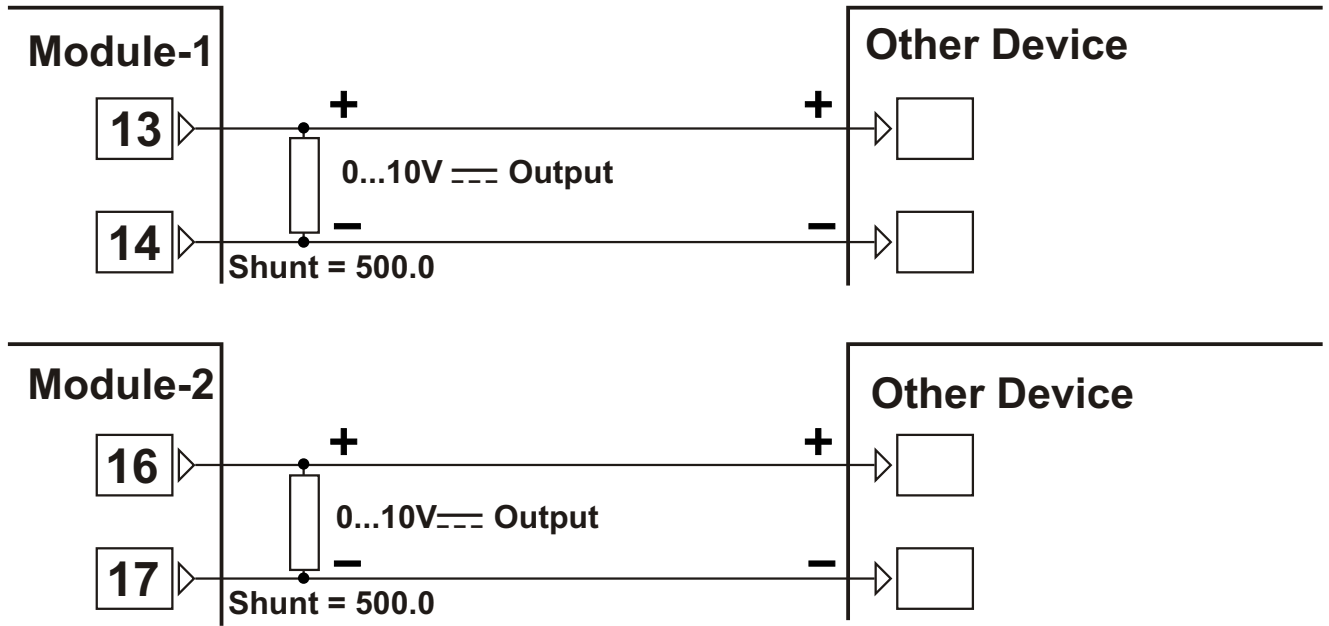

6.Connections for RS-232 / RS-485 Serial Communication

RS-232 Terminal Definitions

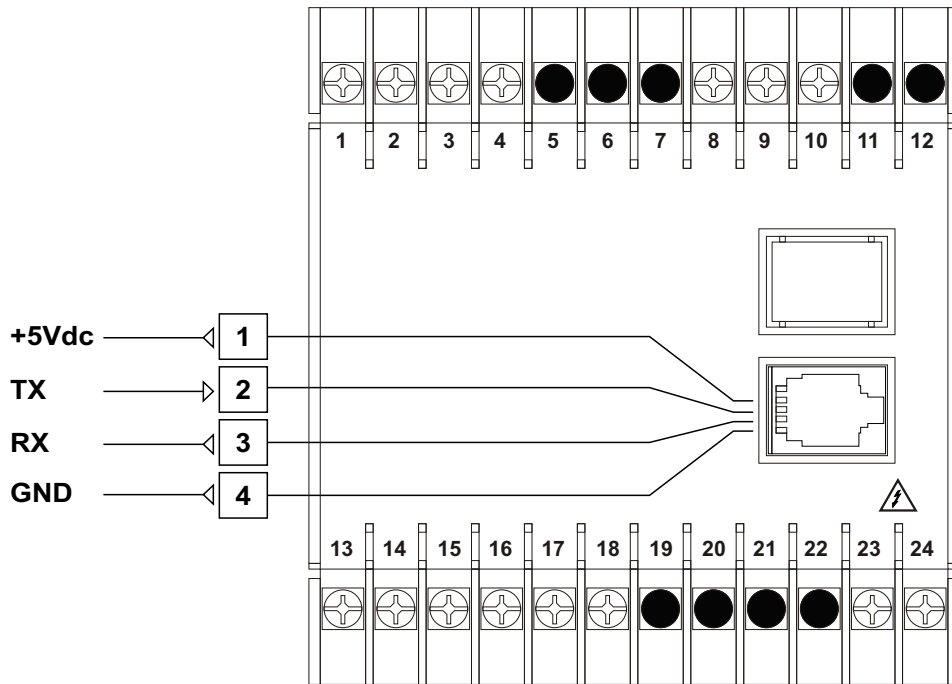

RS-485 Terminal Definitions

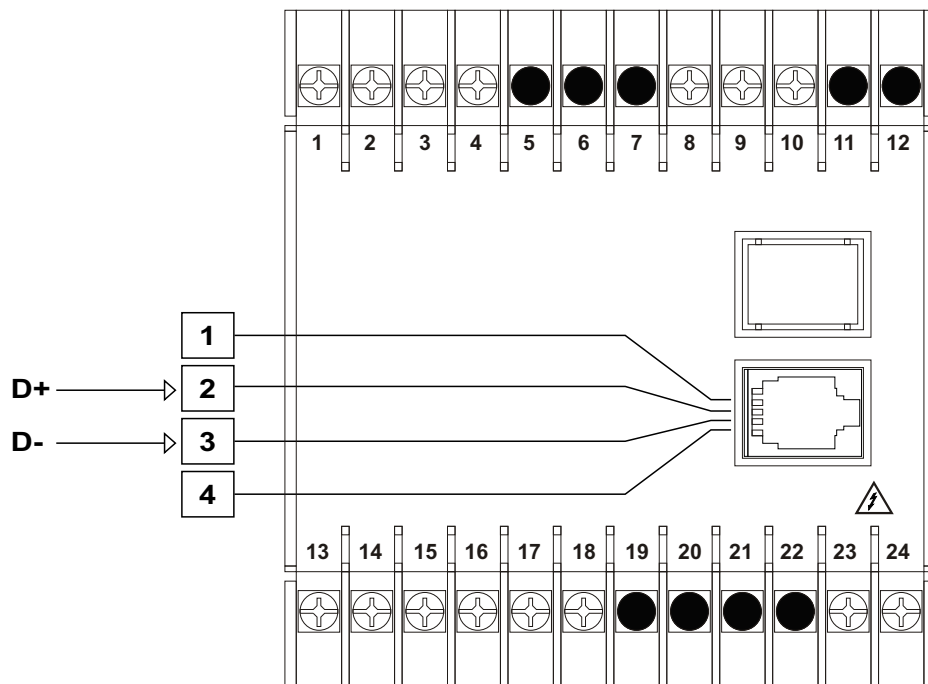

6.1 Cable Connection Between RS-232 Terminal of the Device and PC

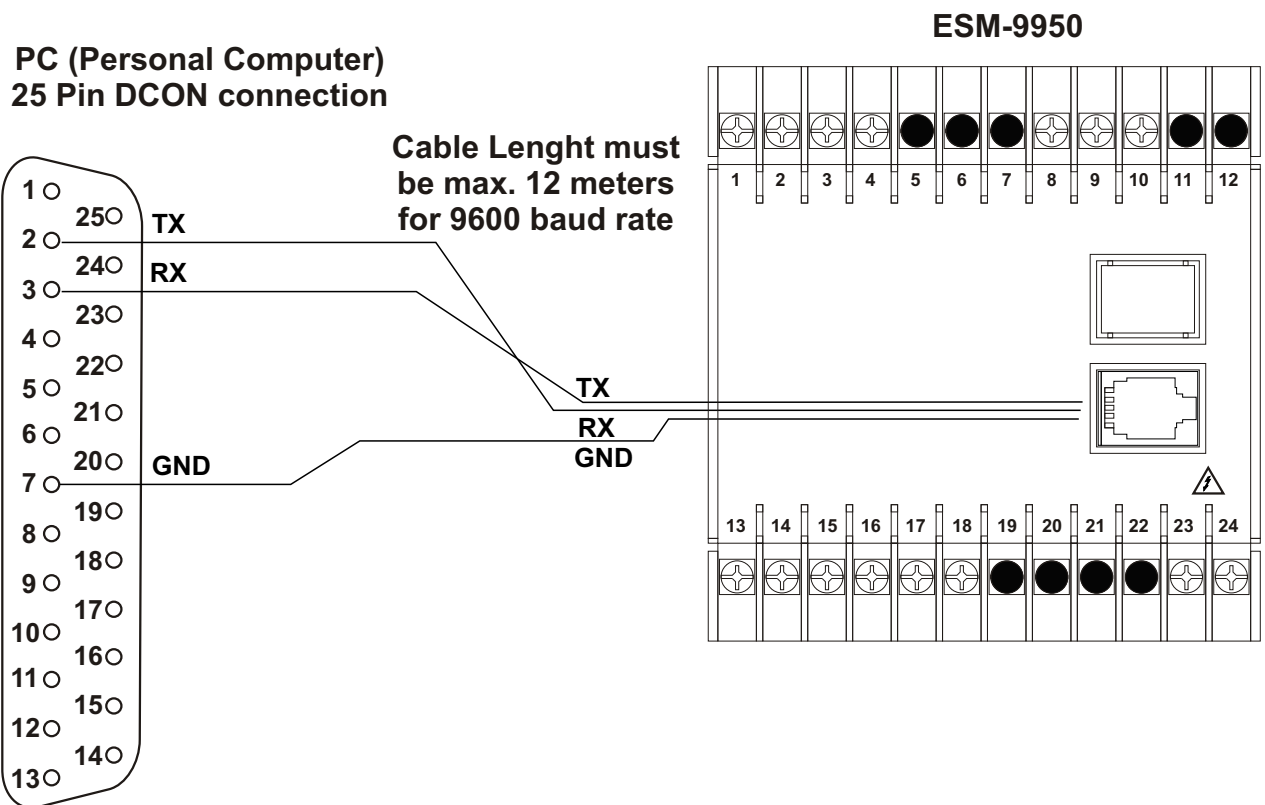
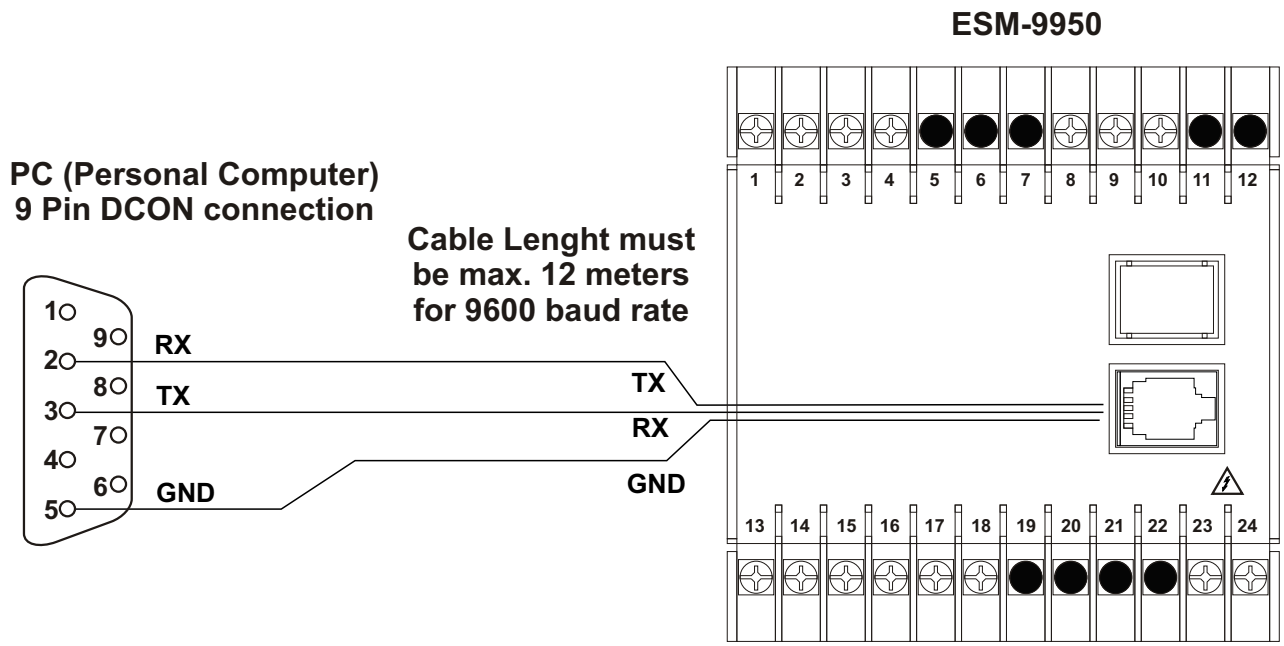

6.2 Connection for RS-485 Serial Communication

PC(Personal Computer)

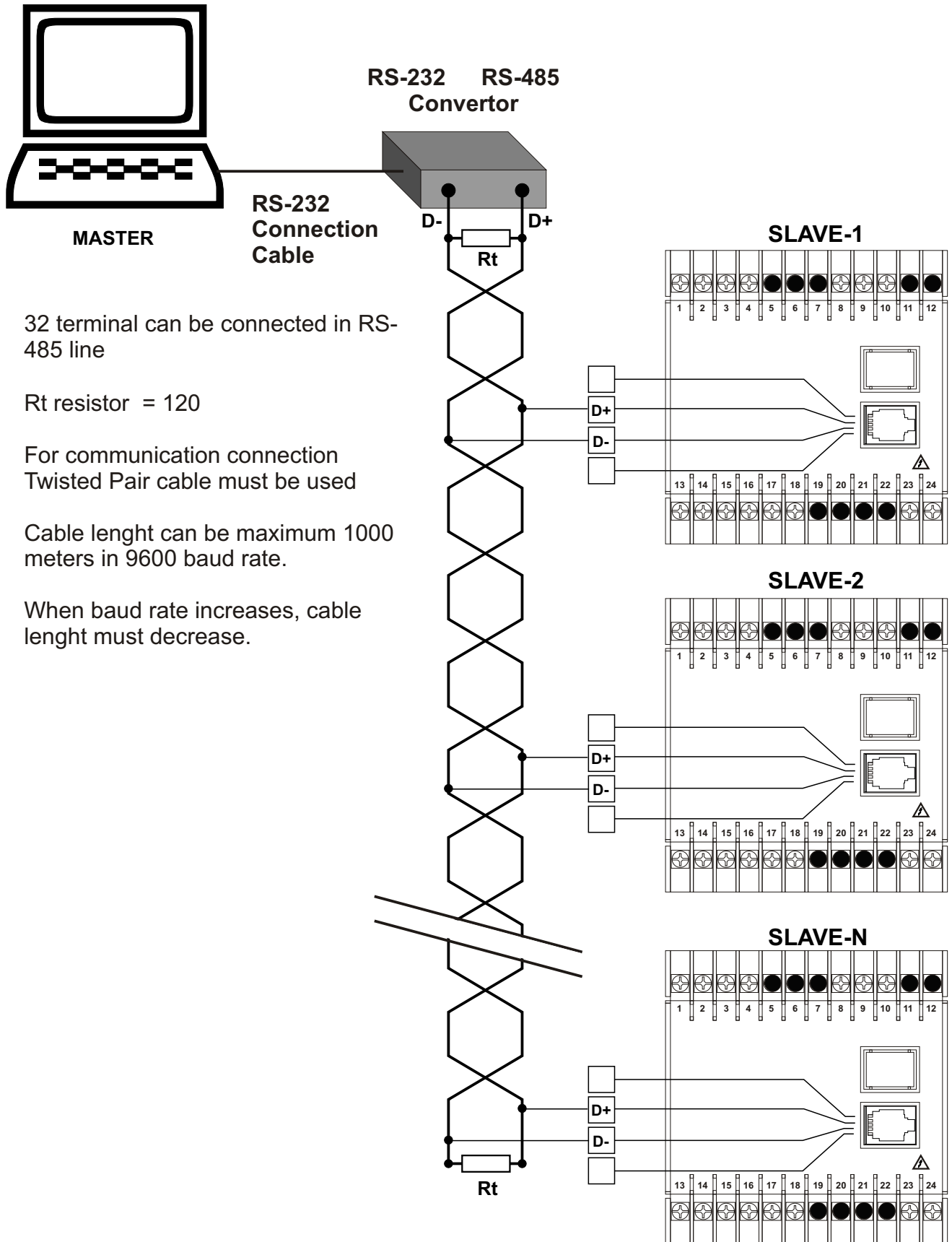

32 terminal can be connected in RS-485 line

R_t resistor = 120

For communication connection
Twisted Pair cable must be used

Cable length can be maximum 1000
meters in 9600 baud rate.

When baud rate increases, cable
length must decrease.

6.3 Installing RS-232 / RS-485 Serial Communication Modules to the Device

Pull the cover case with your hand through rear side as explained in "Installing and Pulling Out Output Modules" section. Pull the modules in Module-1 and Module-2 socket through rear side. Separate supply card which is at the bottom of the equipment by lifting the locking tabs located on front panel. Pay attention to cable connection between top and bottom cards. Damages in this cable makes the equipment not to work.

RS-232 or RS-485 module is plugged into socket signed as A and B. Hold the equipment to be it's front panel is on your right, communication socket is on your left and module connection socket with 5 terminals on above. Plug in module connection socket with 5 terminals to the socket on Top Card. Do the same things for terminal socket in bottom card and connection socket with 3 terminals. Plug in bottom card to the place in front panel. Install the modules which are pulled out to Module-1 and Module-2 socket. Replace the cover case by taking care of the terminal numbers should be at right position.

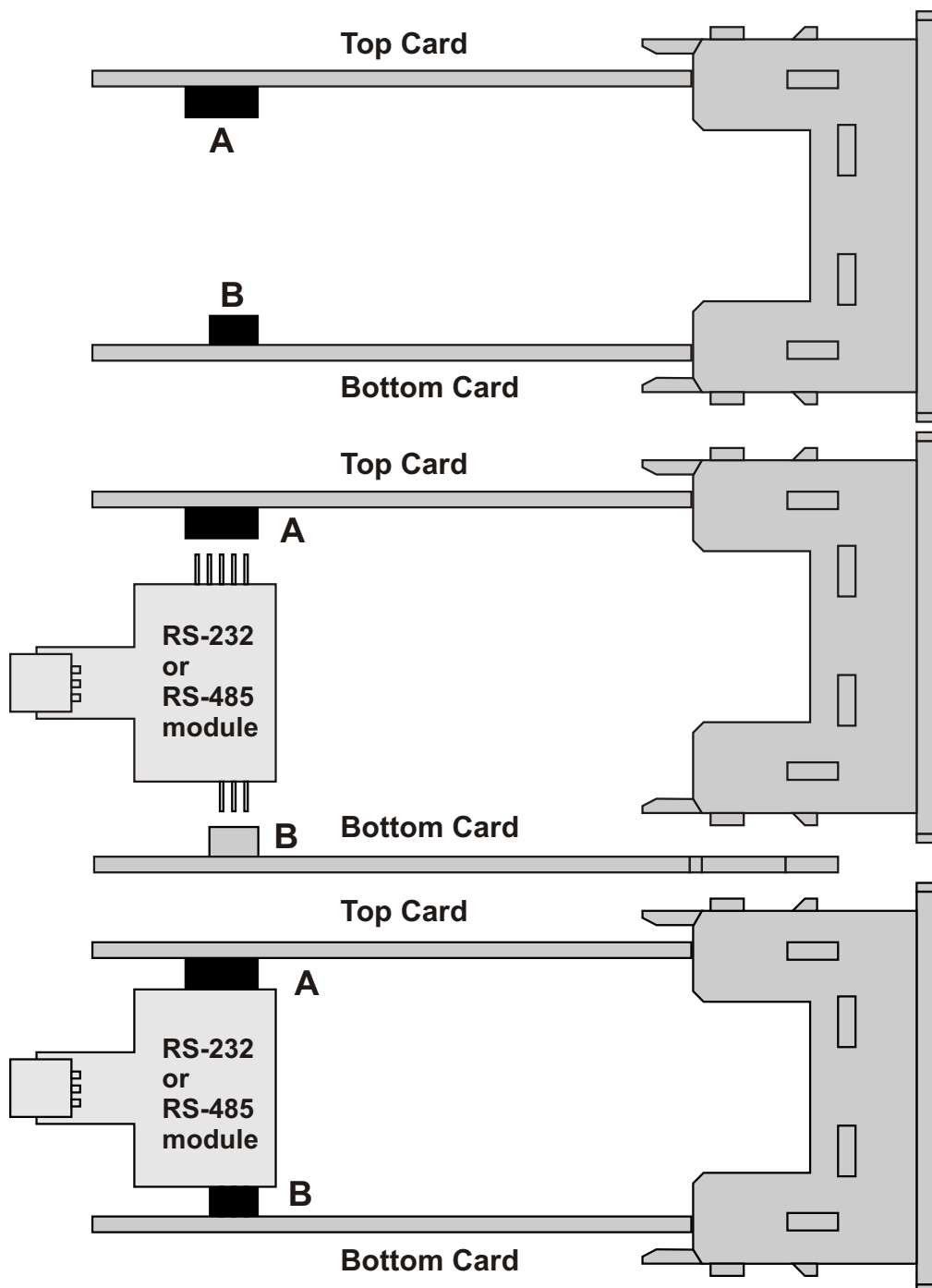

7. Definition of Front Panel and Accessing to the Parameters

7.1 Definition of Front Panel

LED indication of °C : Centigrade Unit

LED indication of °F
Fahrenheit Unit

LED indication of units
other than °C and °F

LED indication of
Output-1 Status

LED indication of
Output-2 Status

LED indication of
Output-3 Status

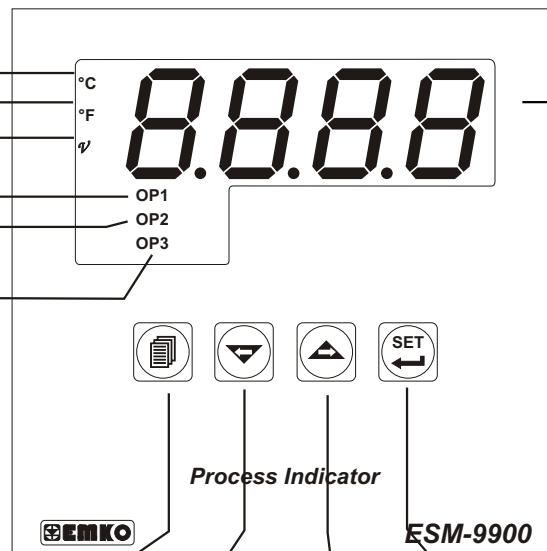

Displays
Process Value
(PV) and
Parameter

Menu button
This button is used
to access to the all
menus and to
move up to another
menu in the menu
list

Note-1
This button is used
to decrease the
values, access to
the menu pages,
cancel alarm
latching

Note-1
This button is used
to increase the
value and access to
the menu pages

This button is used
to access to the
process set value
and use as OK
button in program
parameters.

Note-1: If increment or decrement button is pressed for 5 seconds continuously, increment and decrement number become 10, if increment or decrement button is pressed for 10 seconds continuously, increment and decrement number become 100.

7.2 Observation of Optional Modules and Software Revision on the Displays

There are two sockets for plugging optional modules to the device. These modules are recognized by the device automatically. When the power is applied to the device all led indicators and display segments are momentarily illuminated for testing. Software revision number of the controller on the bottom display and module definition codes on the top display are momentarily illuminated. Module definition codes and how to observe these codes of optional modules in Module-1 and Module-2 socket are explained below :

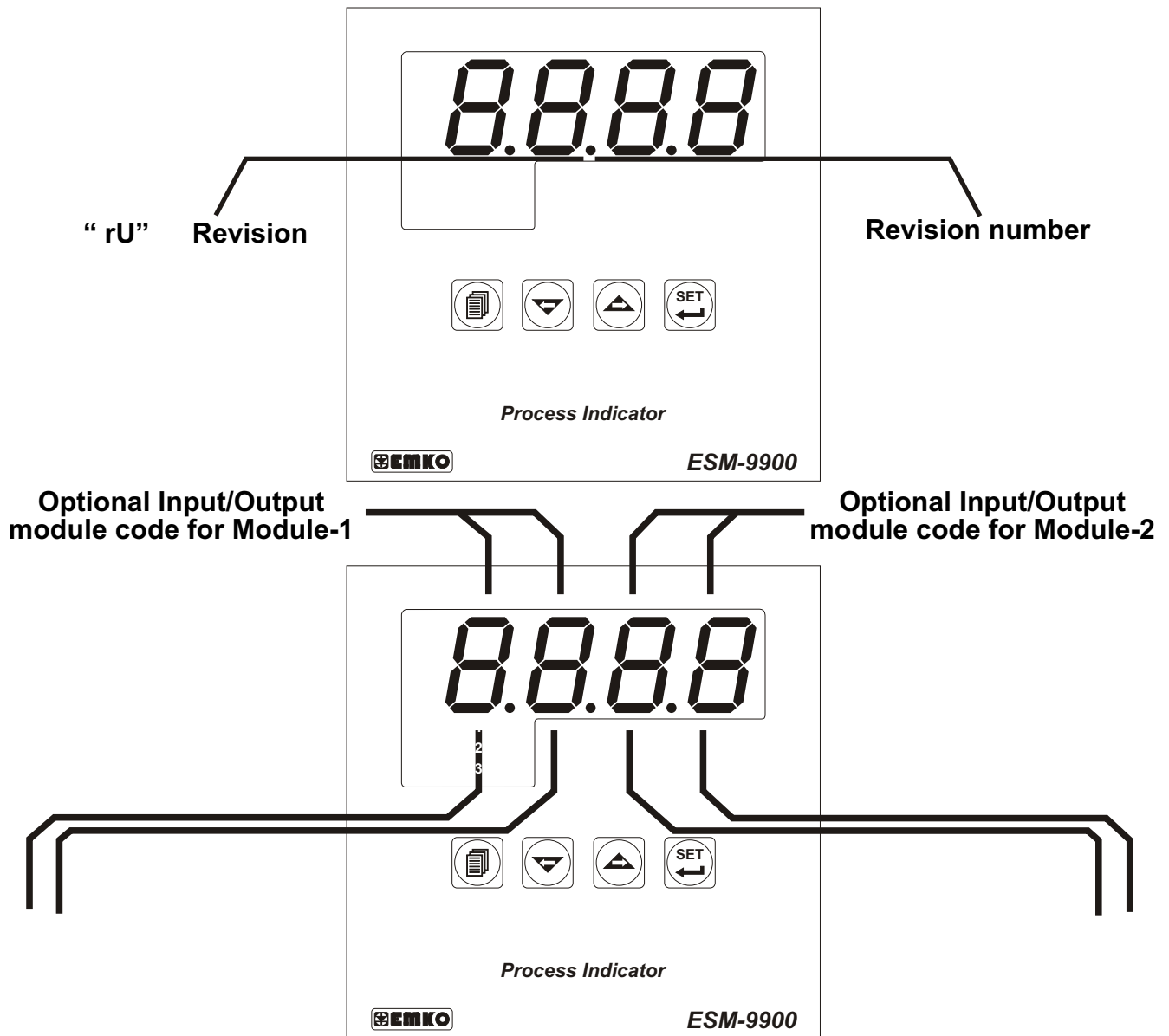

0r	Relay Output Module (EMO-900)	Relay Output Module (EMO-900)	0r
05	SSR Driver and Digital Output Module (EMO-910 ,EMO-920)	SSR Driver and Digital Output Module (EMO-910 ,EMO-920)	05
0A	0/4...20mA---Current Output Module (EMO-930)	0/4...20mA---Current Output Module (EMO-930)	0A
E	There is no module in Module-1 socket	There is no module in Module-2 socket	E

When power on, display of the indicator is like below:

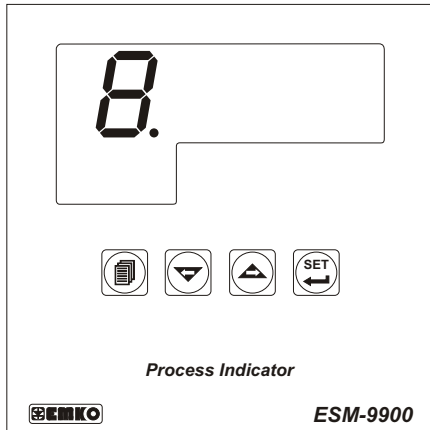

First segments of top and bottom displays are tested

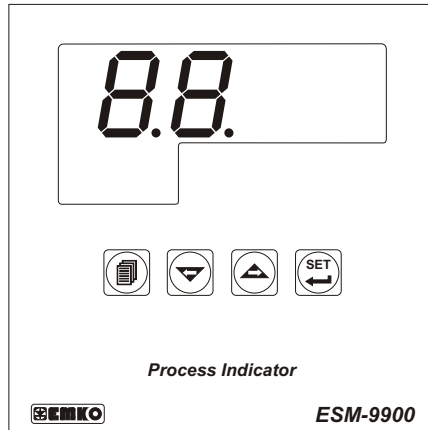

Second segments of top and bottom displays are tested.



Third segments of top and bottom displays are tested.



Fourth segments of top and bottom displays are tested.

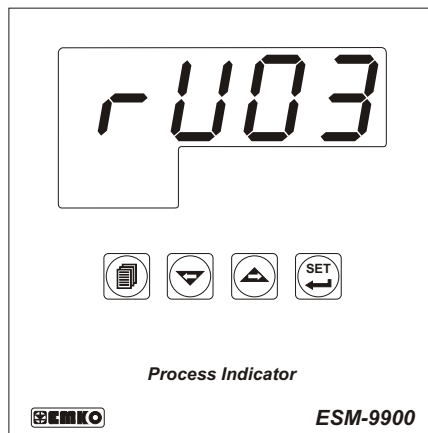

Revision number is shown.
Revision number is "02".

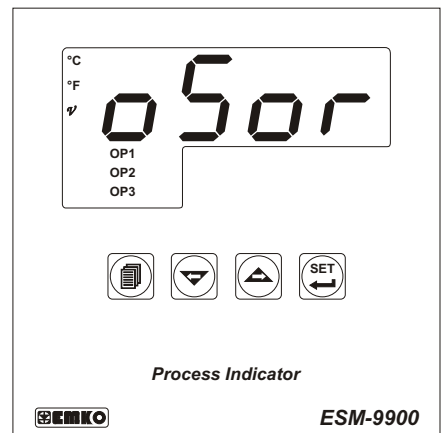

On display which modules are plugged in Module-1 and Module-2 socket is shown. All leds are energised. Above, there is EMO-910 SSR Driver Output module in Module-1 socket and EMO-900 Relay Output Module in Module-2 socket.



Main operation screen is shown



If there is an unexpected situation while opening the device, power off the device and inform a qualified personnel.

7.3 Adjustment of Alarm Set Values

If standard output (Output-3) or any output module in Module-1 or Module-2 socket are configured as alarm output, how to access to these alarm set values are explained below:

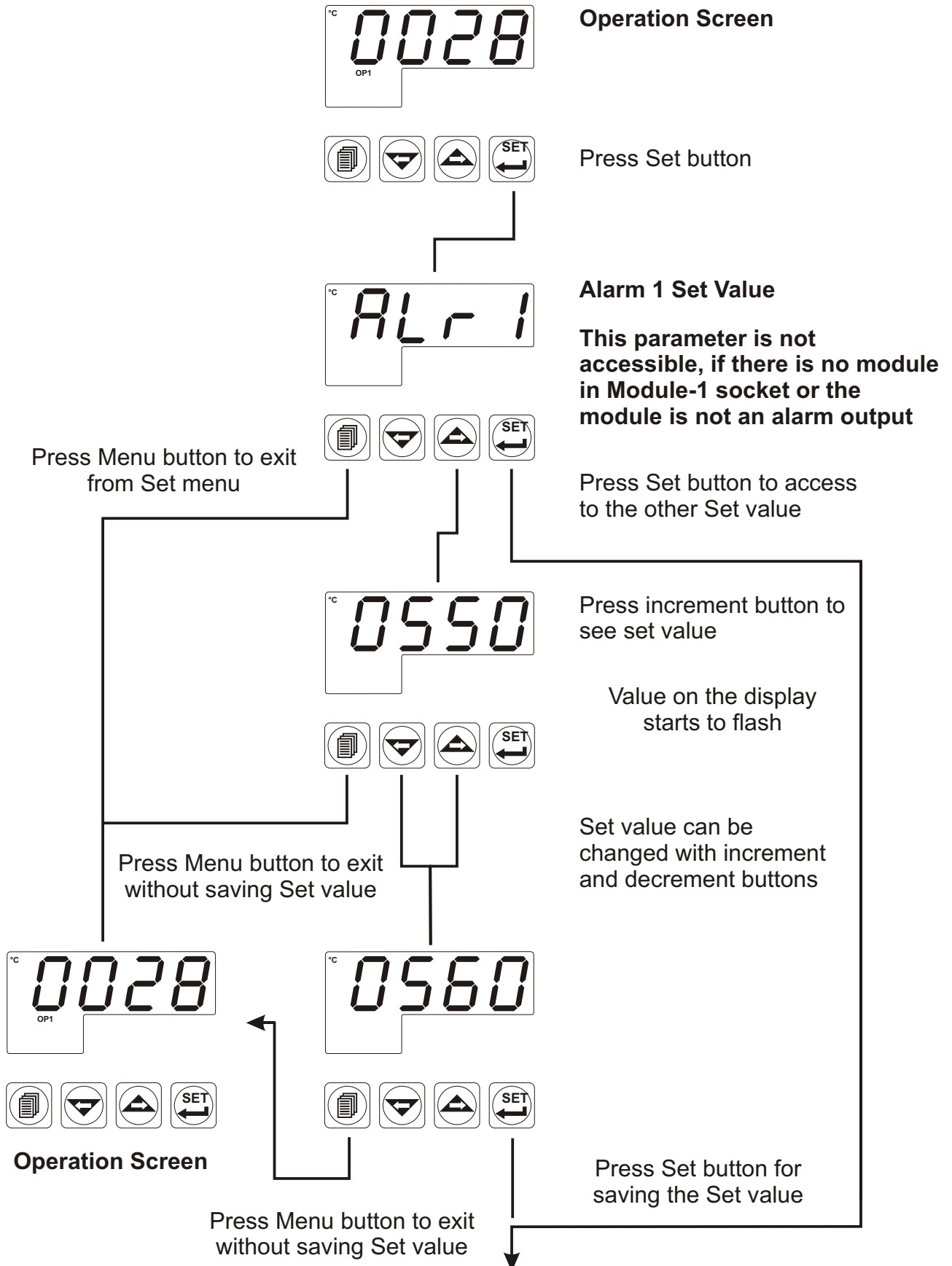

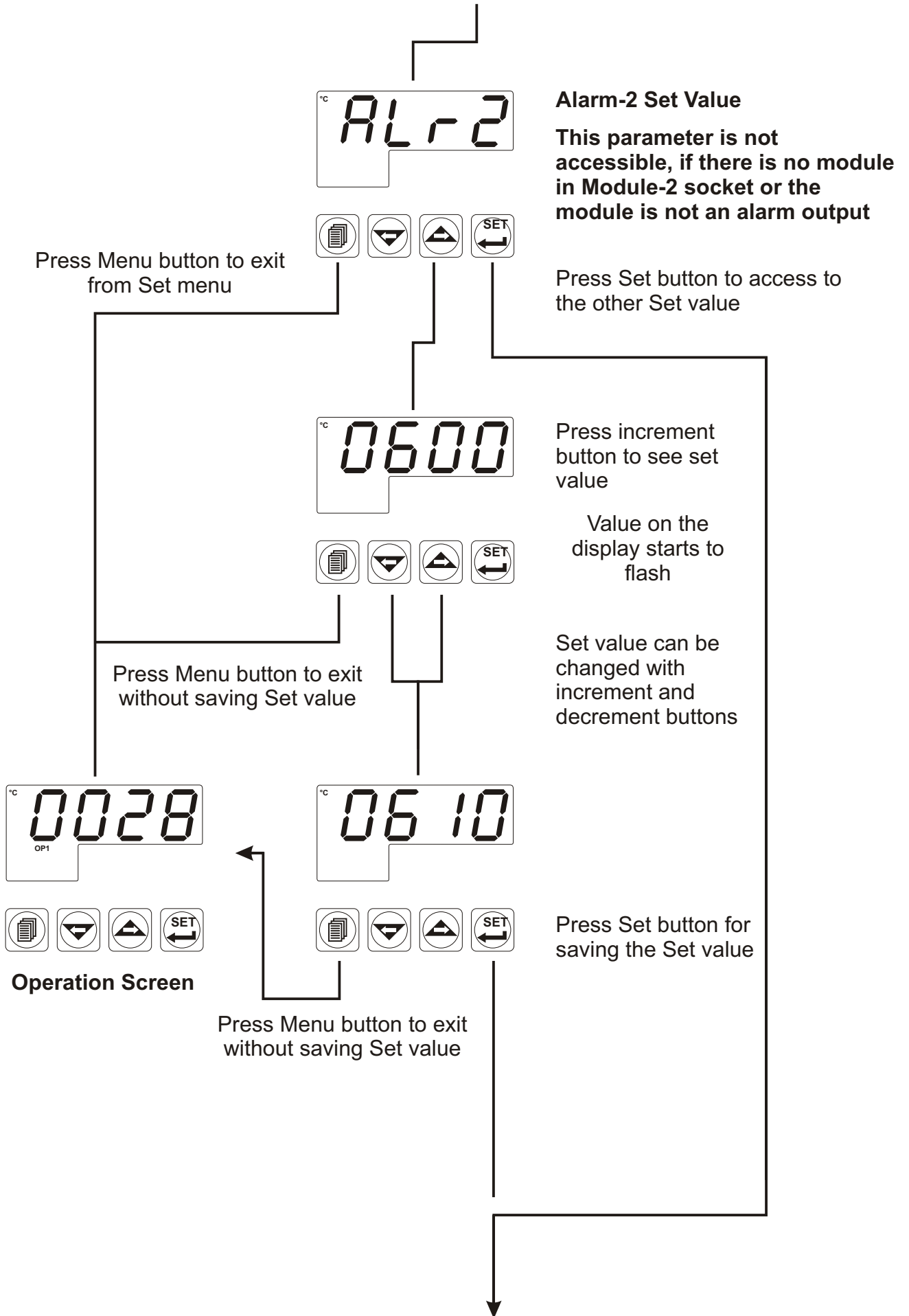

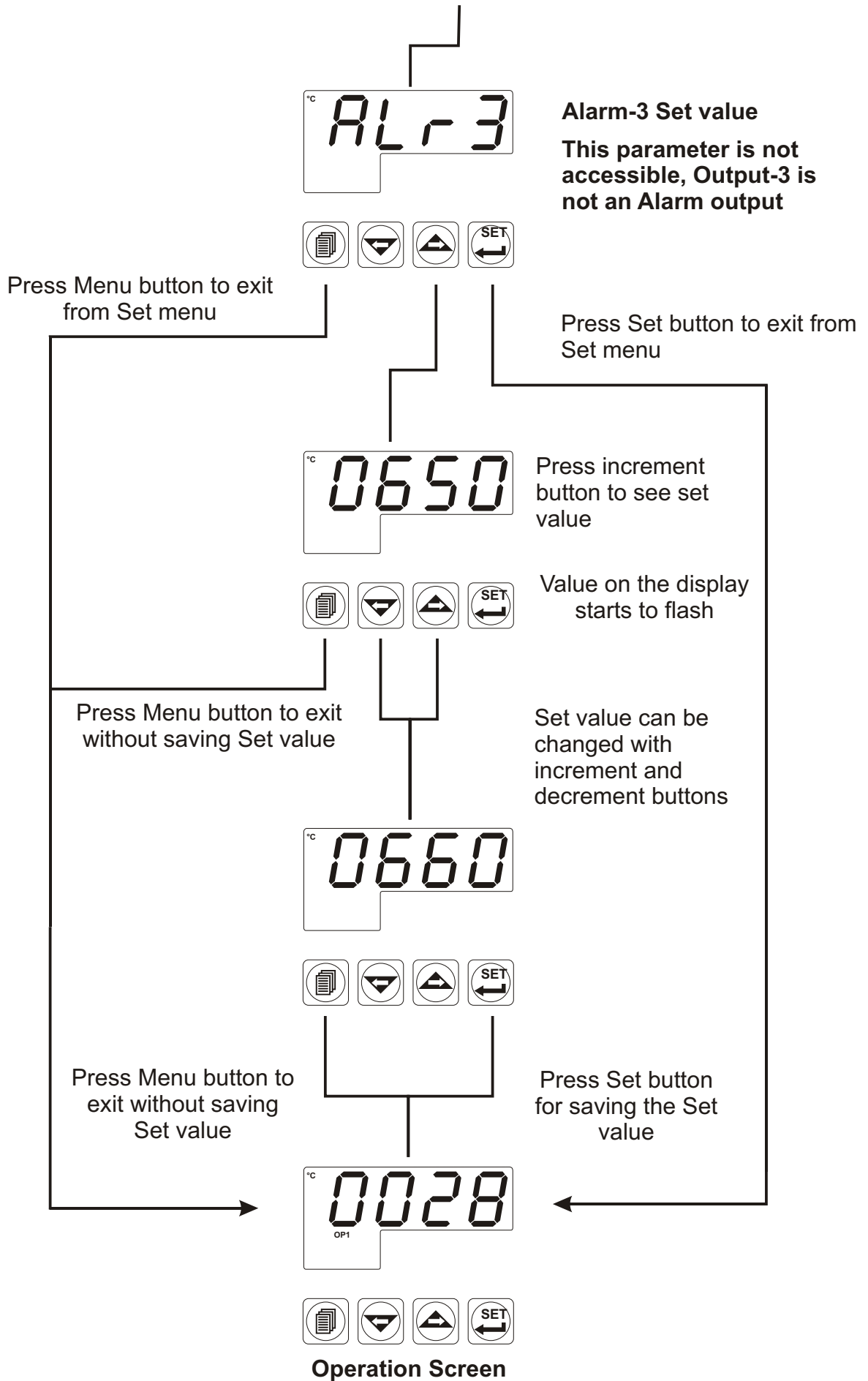

7.4 Easy Access Diagram for Technician Parameters

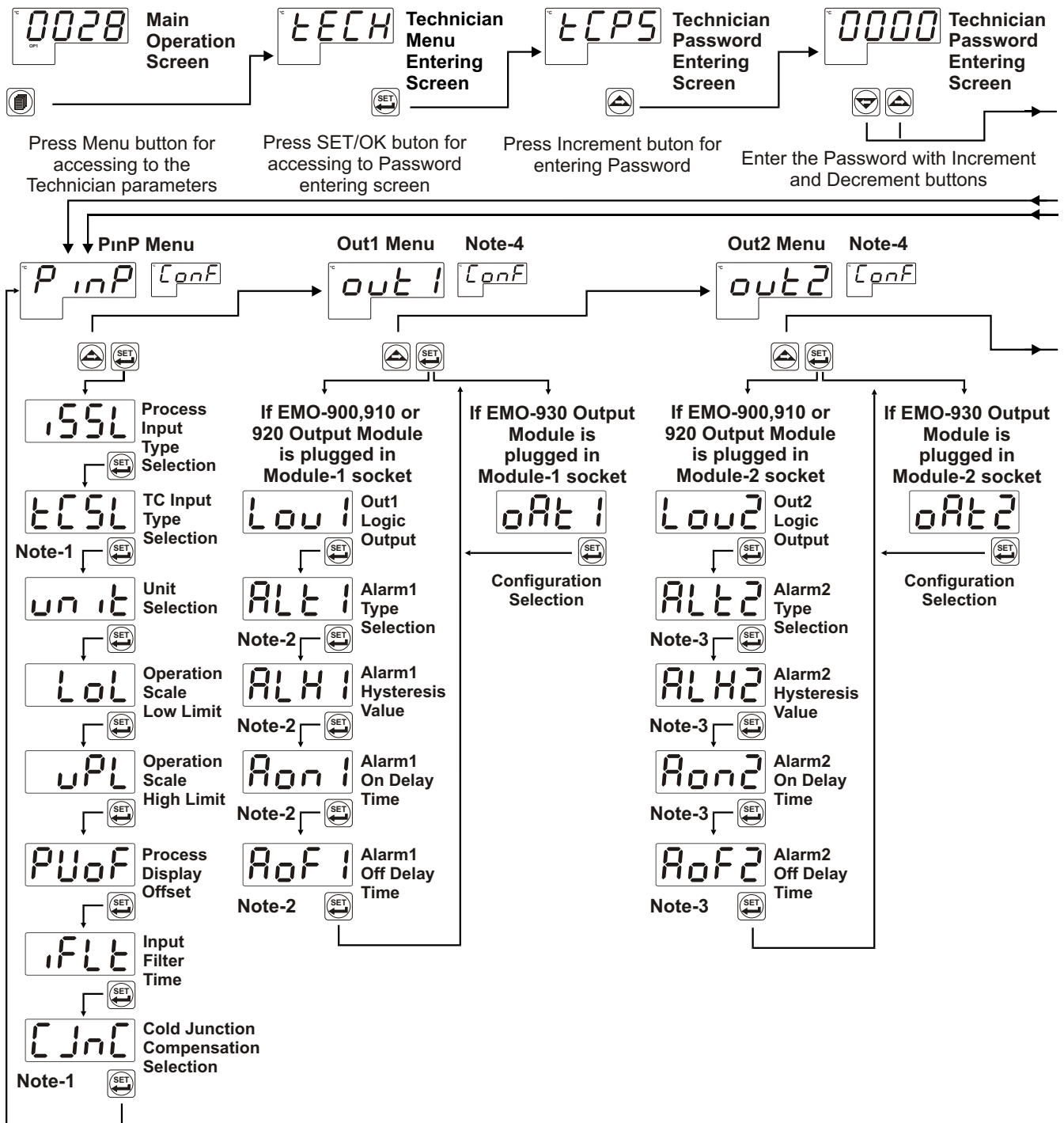

Note-1 : According to the `iSSL` parameter selection, another parameter can be observed instead of `tCSL` parameter and `CJnC` parameter can not be observed.

Note-2 : It can be observed if logic output function `Low1` is selected `0000` as alarm output.

Note-3 : It can be observed if logic output function `Low2` is selected `0000` as alarm output.

Note-4 : This menu can not be observed if there is no module in the module socket.

7.4 Easy Access Diagram for Technician Parameters

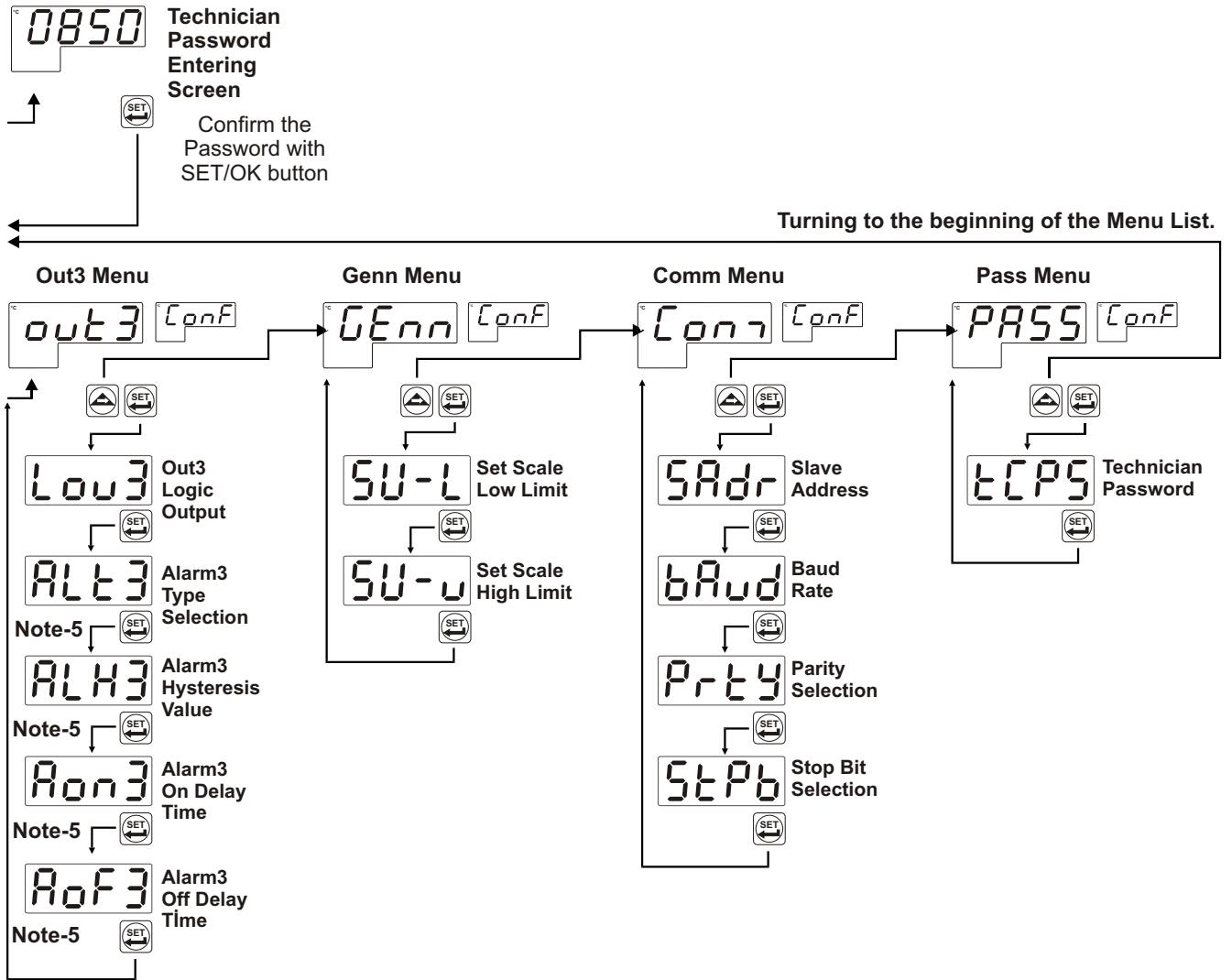

Note-5 : It can be observed if logic output function **Lou3** is selected **0000** as alarm output

7.5 Accessing to the Technician Menu

The parameters have been divided into groups according to their functions. Every group has a title and firstly user must determine the title (menu) for accessing to the parameters. Refer to the parameters section for detailed information about parameters.

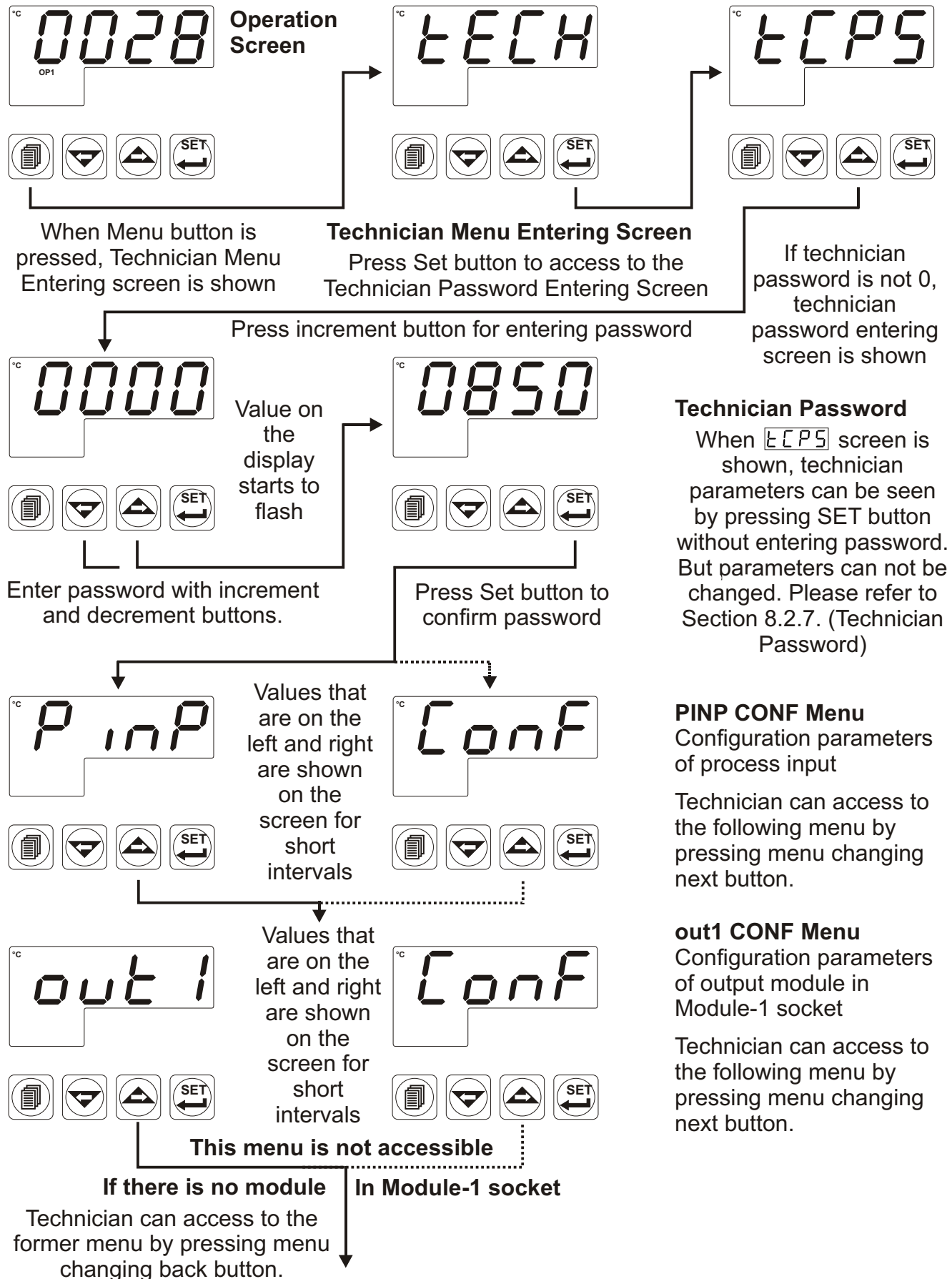

This menu is not accessible | If there is no module in Module-2 socket

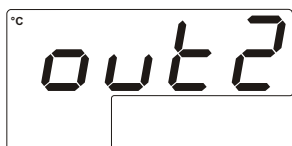

Values that are on the left and right are shown on the screen for short intervals



Technician can access to the former menu by pressing menu changing back button.

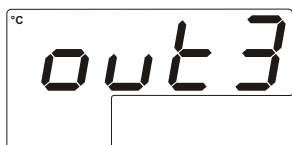

Values that are on the left and right are shown on the screen for short intervals



Technician can access to the former menu by pressing menu changing back button.



Values that are on the left and right are shown on the screen for short intervals



Technician can access to the former menu by pressing menu changing back button.



Values that are on the left and right are shown on the screen for short intervals



Technician can access to the former menu by pressing menu changing back button.

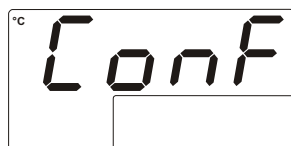

out2 CONF Menu
Configuration parameters of output module in Module-2 socket

Technician can access to the following menu by pressing menu changing next button.



out3 CONF Menu
Configuration parameters of Output-3

Technician can access to the following menu by pressing menu changing next button.



GENN CONF Menu
General Parameters

Technician can access to the following menu by pressing menu changing next button.



COM CONF Menu
Configuration parameters of serial communication

Technician can access to the following menu by pressing menu changing next button.

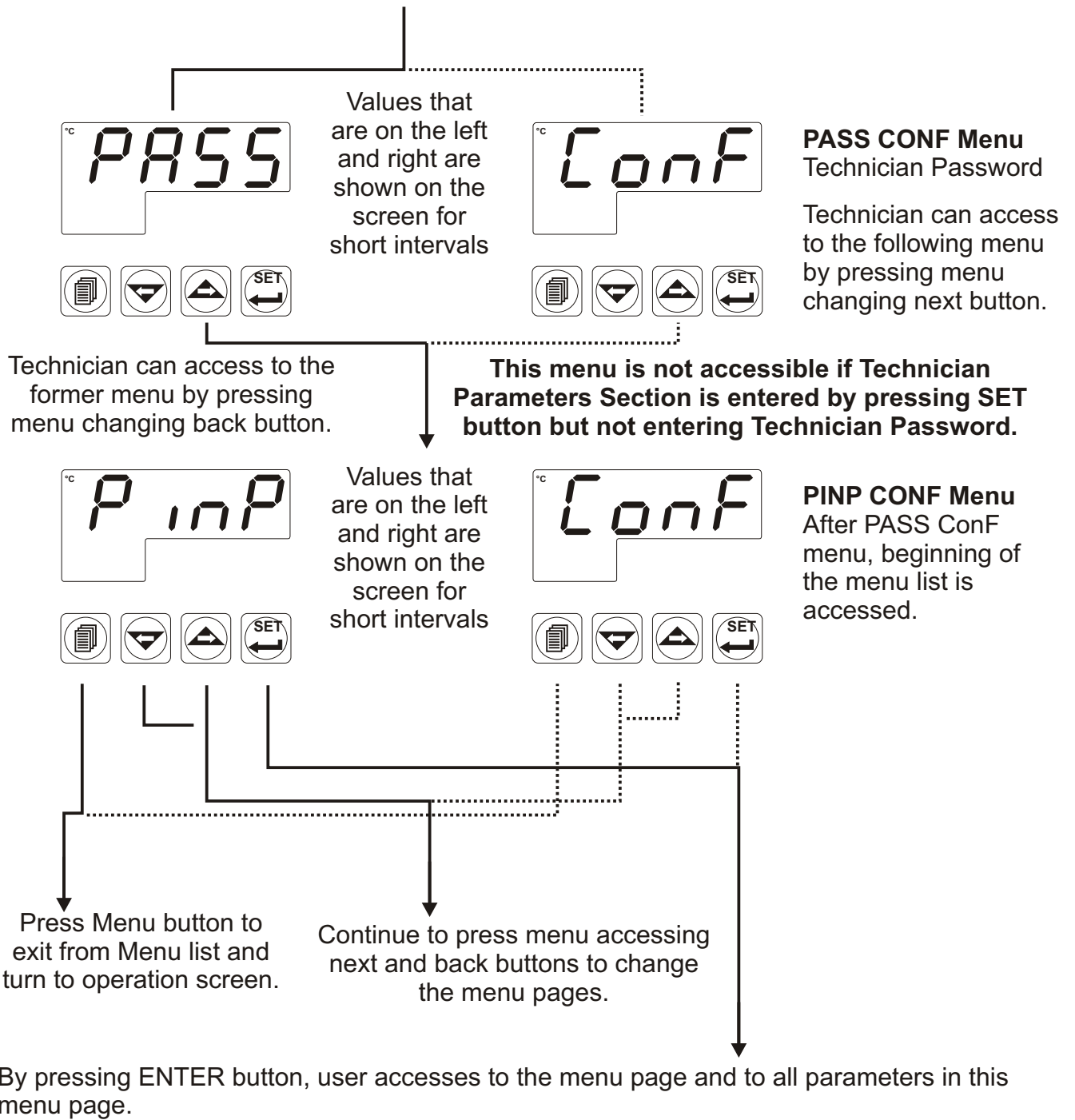

7.6 Changing and Saving Parameters

Example-1 : To change Process Input Type parameter `155L` in “PinP Conf” menu, user must access to PinP ConF menu firstly.

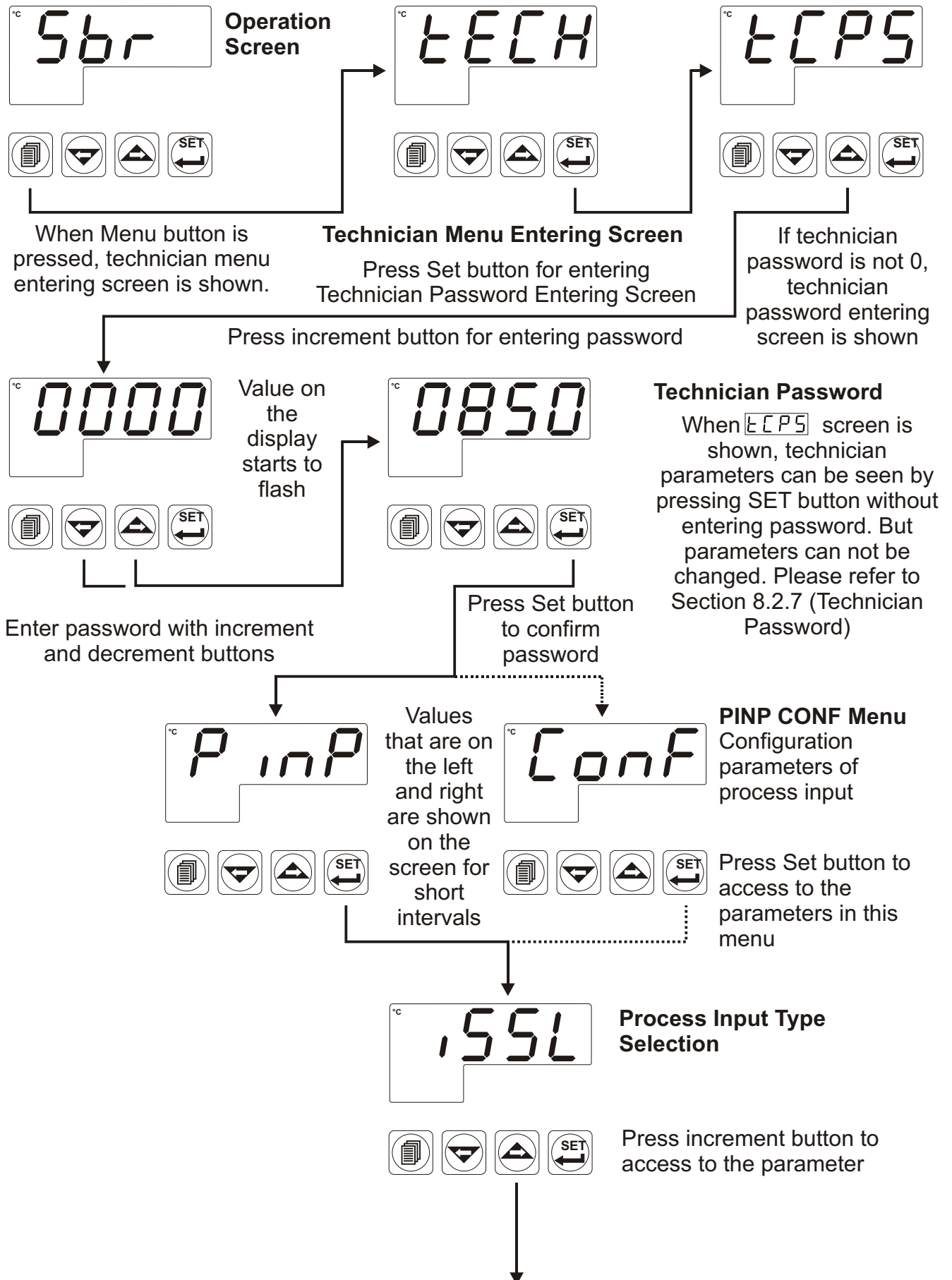

Value on the display starts to flash

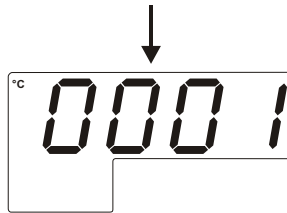

Selection of Process Input Type

0.55L is 0001 means, input type is RTD.



Parameter can be changed with increment and decrement buttons

Value on the display starts to flash



Process Input Type Selection

TC input type is selected



Press Set button to confirm the parameter and access to the next parameter

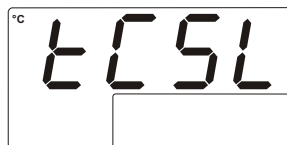

TC Input Type Selection



Press Set button to access to the next parameter

PINP CONF Menu

Press Menu button to access to the menu pages



Values that are on the left and right are shown on the screen for short intervals

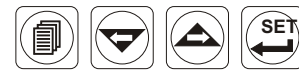
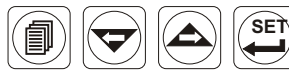

Unit Selection

Press menu changing next or menu changing back button to access to the other menus.

If Menu button is pressed again, operation screen is shown.



Operation Screen

EXAMPLE-2 : To change Alarm Type parameter `ALTE` in “out3 Conf” menu, user must access to out3 Conf menu firstly.

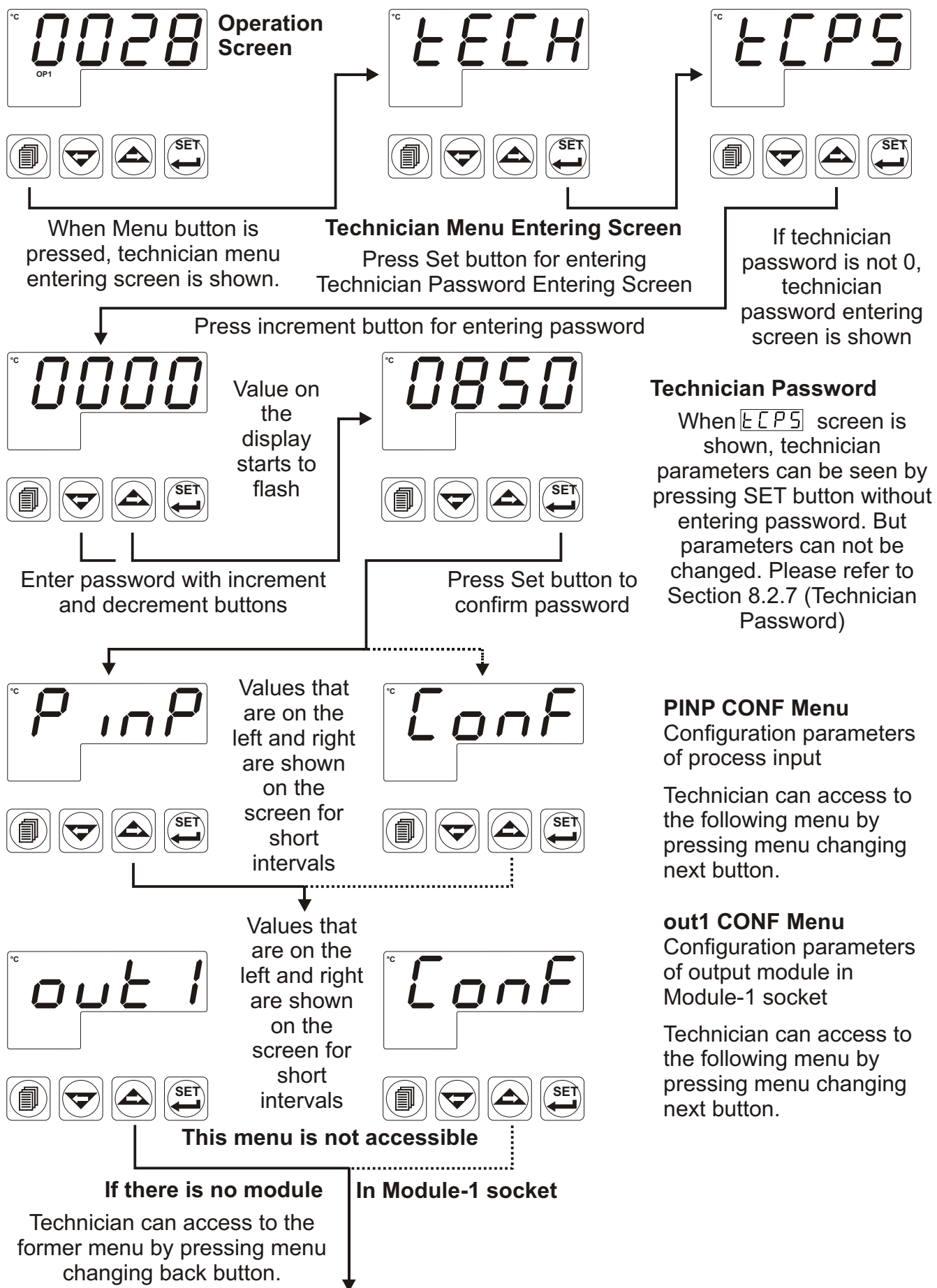

This menu is not accessible | If there is no module in Module-2 socket

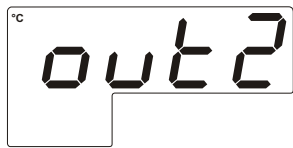

Values that are on the left and right are shown on the screen for short intervals



out2 CONF Menu
Configuration parameters of output module in Module-2 socket



Technician can access to the following menu by pressing menu changing next button.

Technician can access to the former menu by pressing menu changing back button.

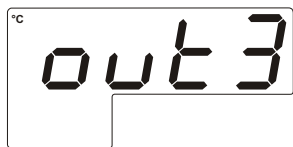

Values that are on the left and right are shown on the screen for short intervals



out3 CONF Menu
Configuration parameters of Output-3



Press Set button to access to the parameter in the menu

Technician can access to the former menu by pressing menu changing back button.

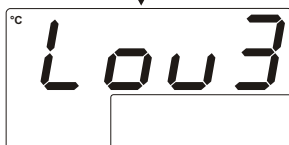

Logic Output Function Selection

Logic Output Function Selection must be 0000



Press Set button to access to the next parameter



Alarm Type Selection



Press increment button to access to the parameter

Value on the display starts to flash



Alarm Type Selection

Process high alarm



Parameter can be changed with increment and decrement buttons

Value on the display flashes



Alarm Type Selection
Process low alarm

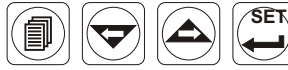

Press Set button to confirm the parameter and access to the next parameter



Alarm Hysteresis Selection



Press Set button to access to the next parameter

Out3 CONF Menu
Press Menu button to access to the menu pages

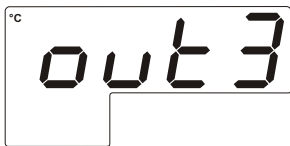

Values that are on the left and right are shown on the screen for short intervals



Alarm on Delay Time

Continue to press menu accessing next and back buttons to change the menu pages.

If Menu button is pressed again, operation screen is shown.



Operation Screen

Example-3 : To change \equiv Voltage/Current Input Calibration Type parameter \square CAL in “PinP Conf” menu

\square CAL Parameter is on “PinP ConF” menu. For accessing to this parameter, technician must access to “PinP ConF” menu firstly. In this example, changing input type of a device from thermocouple to \equiv Voltage/Current and dual point calibration selection is shown.

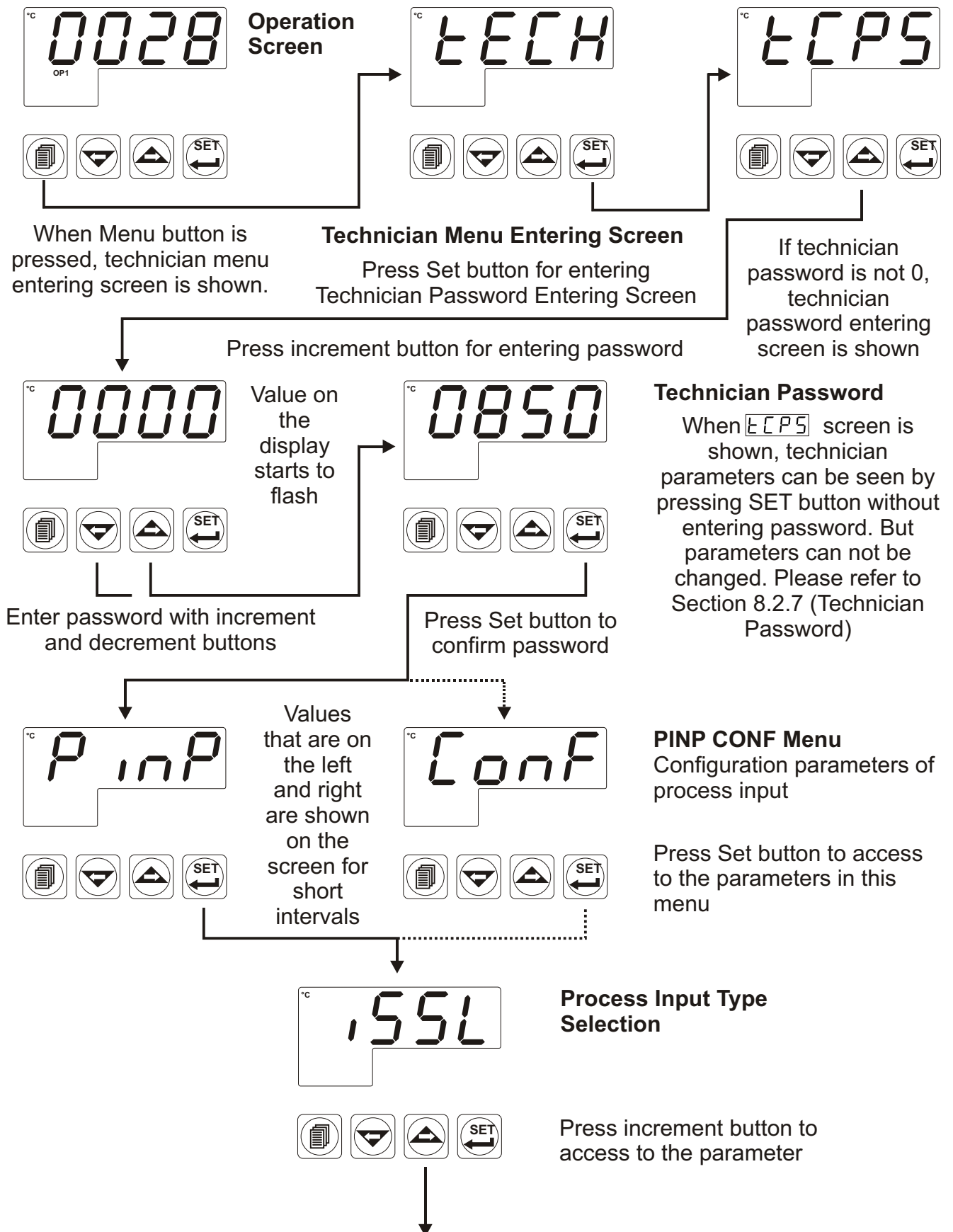

Value on the display flashes

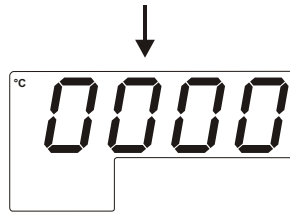

Process Input Type Selection

Parameter can be changed with increment and decrement buttons

Value on the display flashes

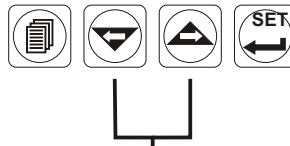

For accessing to `uCAL` Parameter, `1.55L` parameter must be `0002`. If it is not `0002` change the parameter as `0002` With increment button

Press Set button to confirm the value and access to the next parameter

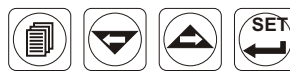

---Voltage / Current Input Type Selection



Press Set button to access to the next parameter

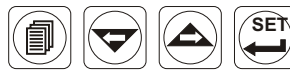

Decimal Point Position

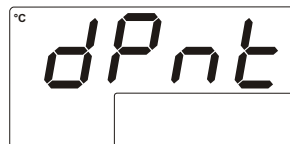

Press Set button to access to the next parameter

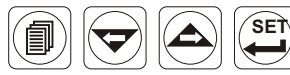

---Voltage / Current Input Calibration Type Selection



Press increment button to access to the parameter

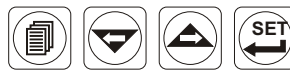

Value on the display starts to flash



Voltage / Current Input Calibration Type Selection

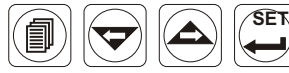

Parameter can be changed with increment and decrement buttons

Value on the display flashes



Voltage / Current Input Calibration Type Selection



Press Set button to confirm the parameter and access to the next parameter

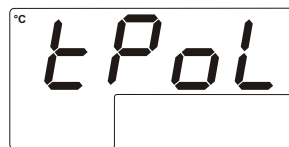

Minimum value for selectable dual point calibration



Press Set button to access to the next parameter

PINP CONF Menu
Press Menu button to access to the menu pages

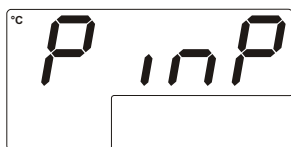

Values that are on the left and right are shown on the screen for short intervals

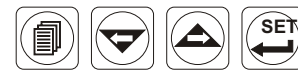
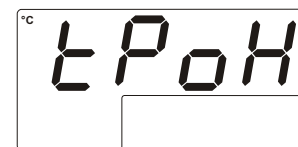
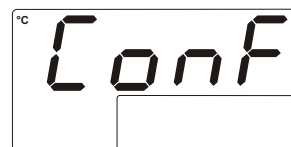

Maximum value for selectable dual point calibration

Continue to press menu accessing next and back buttons to change the menu pages.

If Menu button is pressed again, operation screen is shown.



Operation Screen



8. Parameters

Parameters are divided into two groups. These are Alarm Set and Technician parameters. Technician parameters are grouped into subgroups according to their functions. The subgroups are named as menu pages.

8.1 Alarm SET Parameters

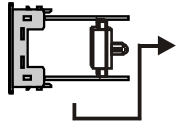

EMO-900
EMO-910
EMO-920

ALr 1

If EMO-900 Relay, EMO-910 SSR Driver or EMO-920 Digital (Transistor) output module is plugged in Module-1 socket and output is configured as an alarm output, this parameter defines the set value of the alarm output.

ALr 1 Set value can be adjusted from minimum value of set scale
SU-L To maximum value of set scale **SU-u**

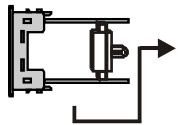

EMO-900
EMO-910
EMO-920

ALr 2

If EMO-900 Relay, EMO-910 SSR Driver or EMO-920 Digital (Transistor) output module is plugged in Module-2 socket and output is configured as an alarm output, this parameter defines the set value of the alarm output.

ALr 2 Set value can be adjusted from minimum value of set scale
SU-L To maximum value of set scale **SU-u**

ALr 3

If OUT-3 relay output module is configured as alarm output, this parameter defines the set value of the alarm output.

ALr 3 Set value can be adjusted from minimum value of set scale
to maximum value of set scale

8.2 Technician Parameters

P_{inP}
Conf

8.2.1 Process Input Type and Relevant Parameters with Process Input

155L

Defines the process input type.

0000

TC input type selection

0001

RTD input type selection

0002

---Voltage/Current input type selection.

155L
0000

tc5L

Defines type and scale of the thermocouple for TC input. It is active if TC input type is selected.

0000

L (-100°C;850°C) or (-148°F;1562°F)

0001

L (-100.0°C;850.0°C) or (-148.0°F;999.9°F)

0002

J (-200°C;900°C) or (-328°F;1652°F)

0003

J (-199.9°C;900.0°C) or (-199.9°F;999.9°F)

0004

K (-200°C;1300°C) or (-328°F;2372°F)

0005

K (-199.9°C;999.9°C) or (-199.9°F;999.9°F)

0006

R (0°C;1700°C) or (32°F;3092°F)

0007

R (0.0°C;999.9°C) or (32.0°F;999.9°F)

0008

S (0°C;1700°C) or (32°F;3092°F)

0009

S (0.0°C;999.9°C) or (32.0°F;999.9°F)

0010

T (-200°C;400°C) or (-328°F;752°F)

0011

T (-199.9°C;400.0°C) or (-199.9°F;752.0°F)

0012

B (44°C;1800°C) or (111°F;3272°F)

0013

B (44.0°C;999.9°C) or (111.0°F ; 999.9°F)

0014

E (-150°C;700°C) or (-238°F;1292°F)

0015

E (-150.0°C;700.0°C) or (-199.9°F;999.9°F)

0016

N (-200°C;1300°C) or (-328°F;2372°F)

0017

N (-199.9°C;999.9°C) or (-199.9°F;999.9°F)

0018

C (0°C;2300°C) or (32°F;3261°F)

0019

C (0.0°C;999.9°C) or (32.0°F;999.9°F)

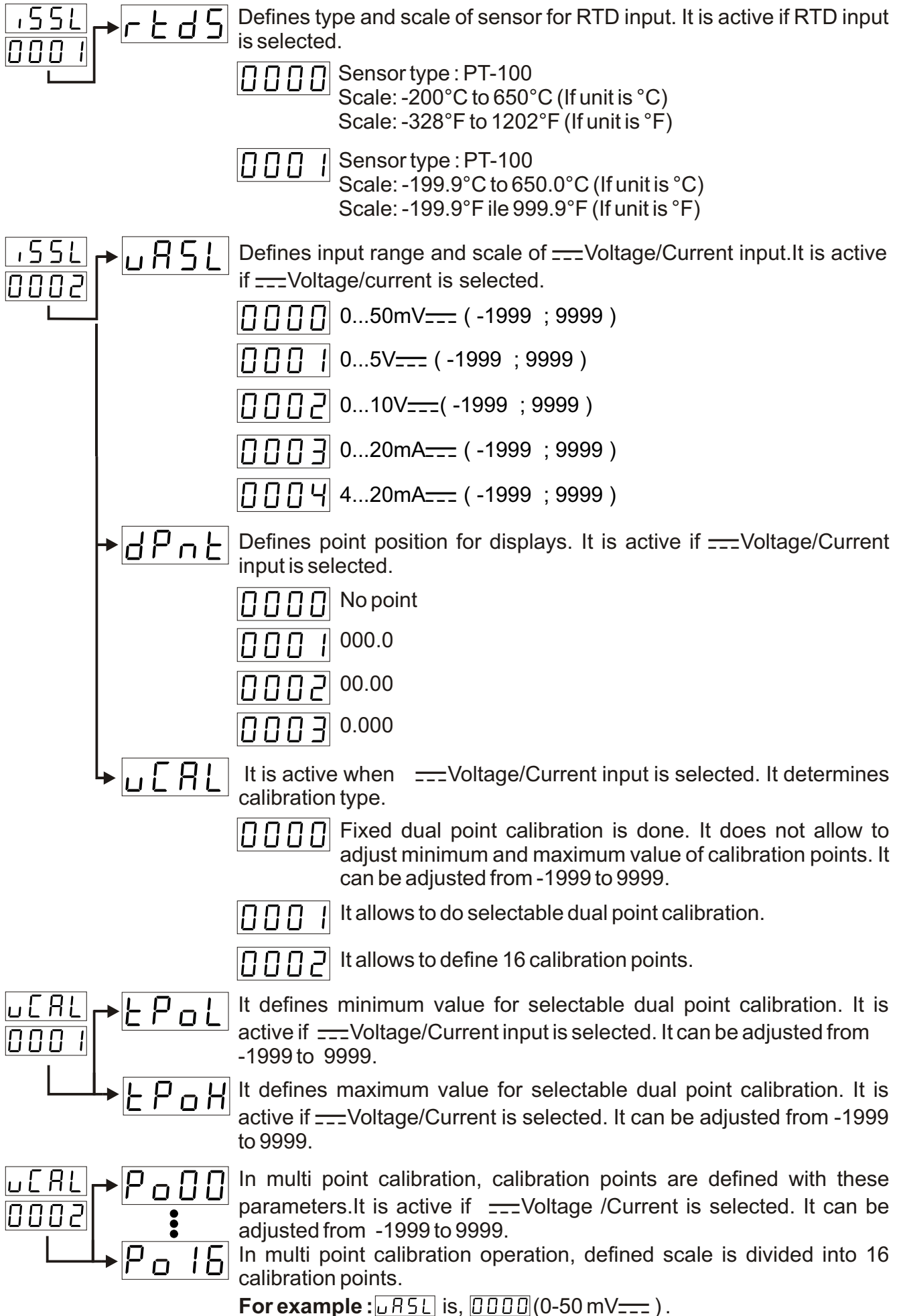

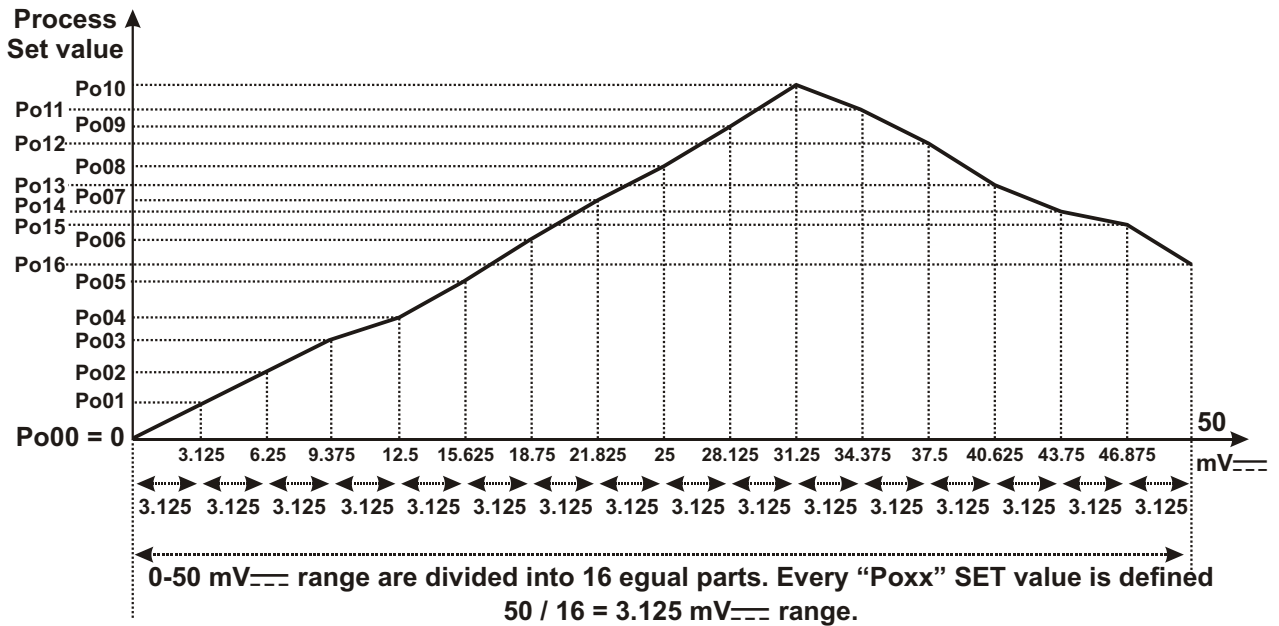

uCAL
0002

COEF

Coefficient value for Voltage /Current input. Process value is multiplied with this value. It is active if Voltage /Current input is selected. It can be adjusted from 1.000 to 9.999.

unit

Unit selection

0C Unit is °C

0F Unit is °F

155L
0002

U

Unit is U. It is active if Voltage /Current input is selected

-

No unit. It is active if Voltage/Current input is selected

LOL

Minimum value of operating scale. It can be changed according to input type and scale of the process.

uPL

Maximum value of operating scale. It can be changed according to input type and scale of the process.

PUoF

Display offset for process value. It can be adjusted -10% to +10% of scale. The defined value is added to process value.

IFLT

Defines filter time for input signal. It can be adjusted from 0.0 to 900.0.

155L
0000

CJnC

It is active if process input is selected TC input. It decides if cold junction compensation is active or not.

YES

Cold junction compensation is active.

no

Cold junction compensation is not active.

out 1

8.2.2 MODULE-1 Configuration Parameters

CONF

Module-1 configuration parameters are arranged automatically by the device according to the module type in Module-1 socket. These parameters are not accessible if there is no module in Module-1 socket.

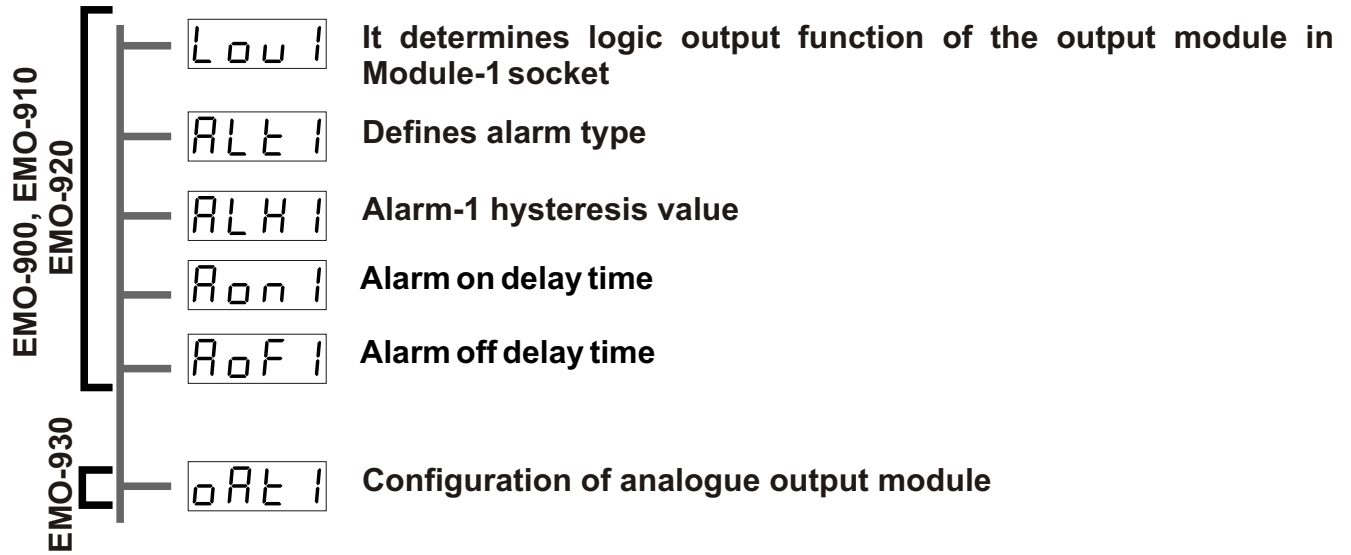

Module-1 configuration parameters are defined according to which output modules are plugged in Module-1 socket.

out 1 CONF



These parameters are active if EMO-900 (Relay Output), EMO-910 (SSR Driver) or EMO-920 (Digital Output) module is plugged in Module-1 socket.

out 1

CONF

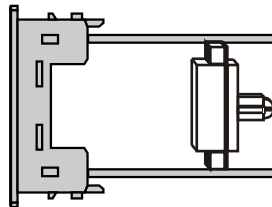

EMO - 900
EMO - 910
EMO - 920

Lou 1 It determines logic output function of the output module in Module-1 socket

0000 Alarm output

0001 Sensor break alarm output

0002 Output is active when the process value is out of the band which is defined with minimum value of operating scale LoL And maximum value of operating scale uPL

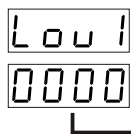

ALt 1 It determines alarm type. It is active if logic output function of Module-1 is adjusted alarm output.

0000 Process high alarm

0001 Process low alarm

Process high alarm

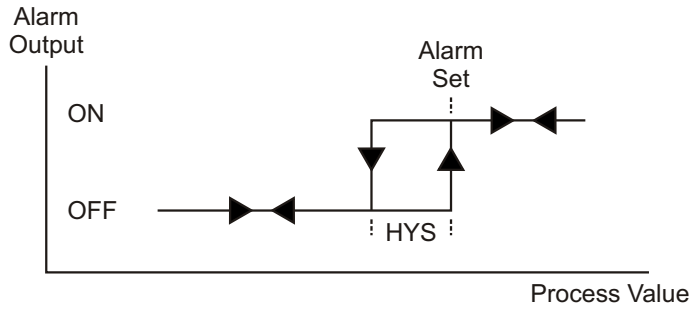

Process low alarm

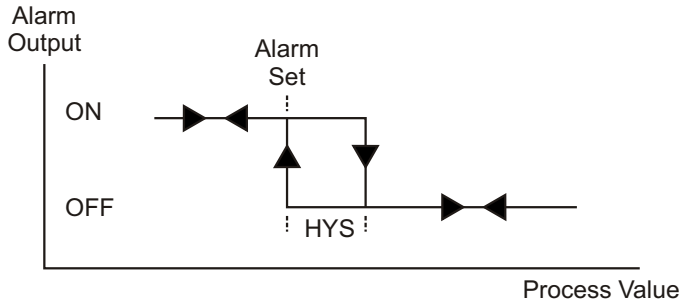

- LoU1 → ALH1 Alarm- 1 hysteresis value. It is active if logic output function of Module-1 is selected alarm output.
 It can be adjusted from 0% to 50% of process input scale
 (uPL - LoL)
- 0000 → Ron1 Alarm on delay time. It can be adjusted from 0000 to 9999 seconds. It is active if logic output function of Module-1 is alarm output.
- 0000 → Rof1 Alarm off delay time. It can be adjusted from 0000 to 9998 seconds. When the value is greater than 9998, LECH is seen on the display. It means alarm latching output is selected. It is active if logic output function of Module-1 is alarm output.

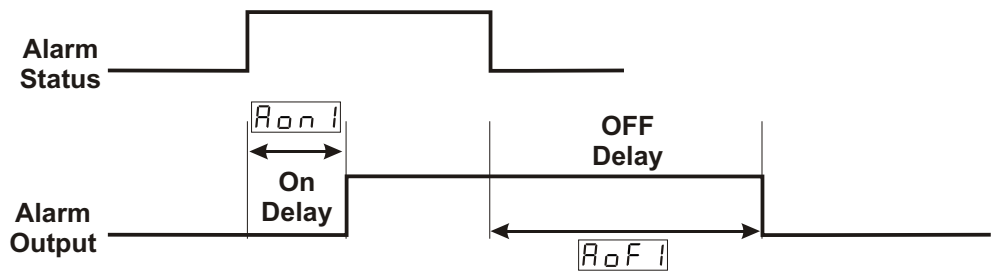

out 1 Conf



These parameters are active if EMO-930 (0/4...20 mA—Current Output) module is plugged in Module-1 socket.

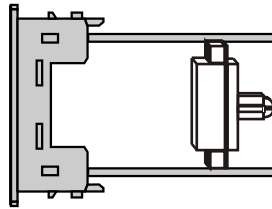

EMO-930

out 1
Conf

oAt 1

Configuration of analogue output module in Module-1 socket.

0000

0...20mA output or 0...10V— according to Section 5.1.5 is selected.

0001

4...20mA output or 2...10V— according to Section 5.1.5 is selected.

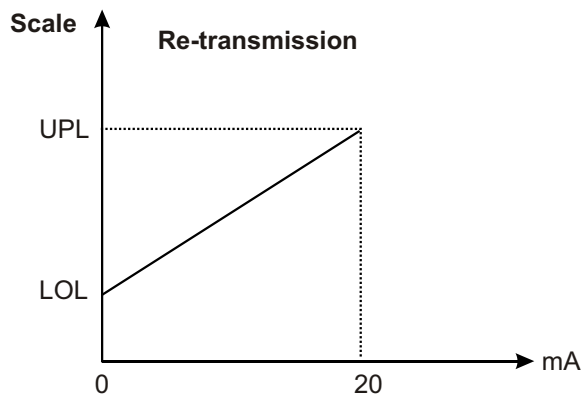

out2

8.2.3 MODULE-2 Configuration Parameters

Conf

Module-2 configuration parameters are arranged automatically by the device according to the module type in Module-2 socket. These parameters are not accessible if there is no module in Module-2 socket.

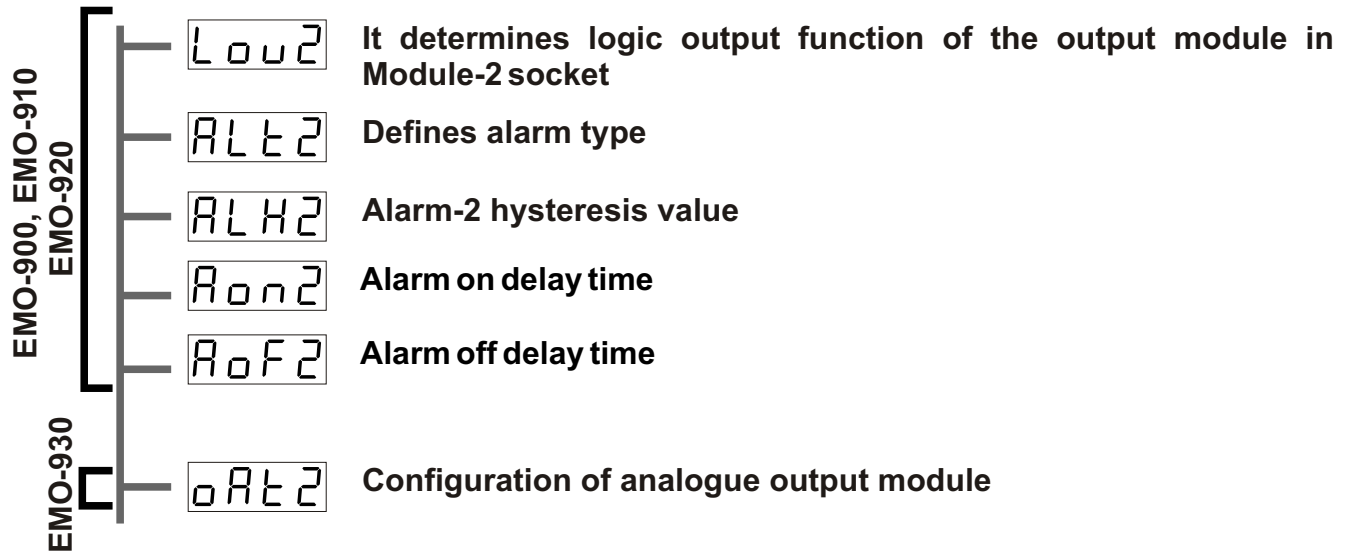

Module-2 configuration parameters are defined according to which output modules are plugged in Module-2 socket.

out2 Conf



These parameters are active if EMO-900 (Relay Output) , EMO-910 (SSR Driver) or EMO-920 (Digital Output) module is plugged in Module-2 socket.

out2

Conf

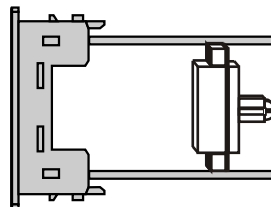

EMO - 900
EMO - 910
EMO - 920

Lou2 It determines logic output function of the output module in Module-2 socket

0000 Alarm output

0001 Sensor break alarm output

0002 Output is active when the process value is out of the band which is defined with minimum value of operating scale

LoL And maximum value of operating scale **uPL**

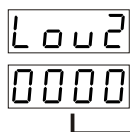

ALt2 It determines alarm type. It is active if logic output function of Module-2 is adjusted alarm output.

0000 Process high alarm

0001 Process low alarm

Process high alarm

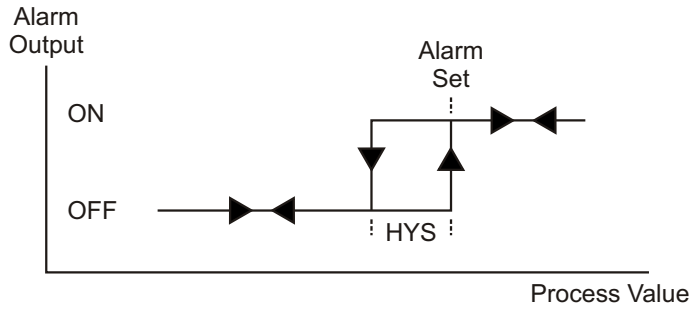

Process low alarm

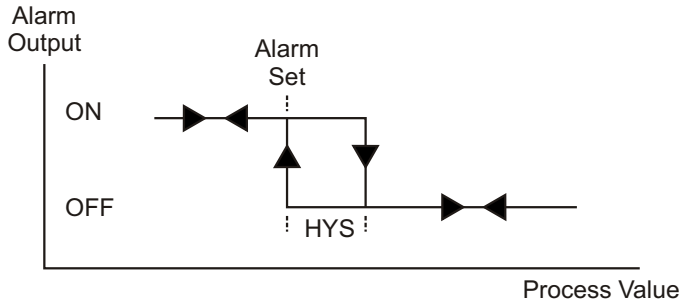

- Lou2
0000

ALH2

Alarm- 2 hysteresis value. It is active if logic output function of Module-2 is selected alarm output.
It can be adjusted from 0% to 50% of process input scale ($\boxed{uPL} - \boxed{LoL}$)
- Ron2

Alarm on delay time. It can be adjusted from 0000 to 9999 seconds. It is active if logic output function of Module-2 is alarm output.
- RoF2

Alarm off delay time. It can be adjusted from 0000 to 9998 seconds. When the value is greater than 9998, **LECH** is seen on the display. It means alarm latching output is selected. It is active if logic output function of Module-2 is alarm output.

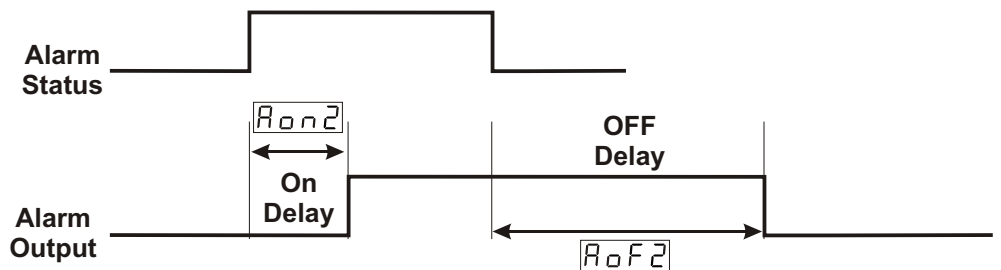

out2 Conf



These parameters are active if EMO-930 (0/4...20 mA \rightleftharpoons Current Output) module is plugged in Module-2 socket.

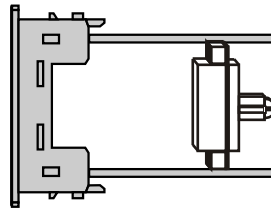

EMO-930

out2
Conf

oArt2

Configuration of analogue output module in Module-2 socket.

0000

0...20mA output or 0...10V \rightleftharpoons according to Section 5.1.5 is selected.

0001

4...20mA output or 2...10V \rightleftharpoons according to Section 5.1.5 is selected.

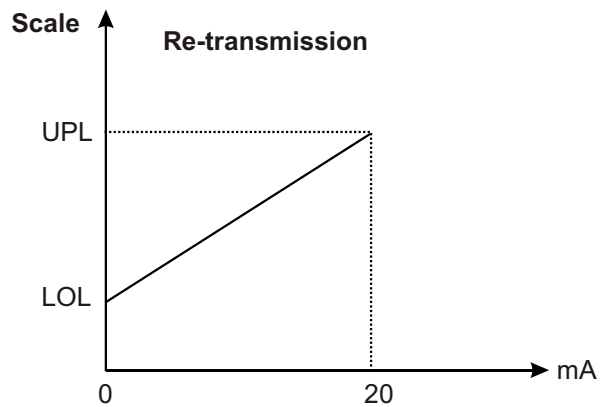

out3

8.2.4 OUTPUT-3 Configuration Parameters

Conf

Lou3

It determines logic output function of Output-3

0000

Alarm output

0001

Sensor break alarm output

0002

Output is active when the process value is out of the band which is defined with minimum value of operating scale

LoL

uPL

Lou3
0000

ALt3

It determines alarm type. It is active if logic output function of Output-3 is alarm output.

0000

Process high alarm

0001

Process low alarm

Process high alarm

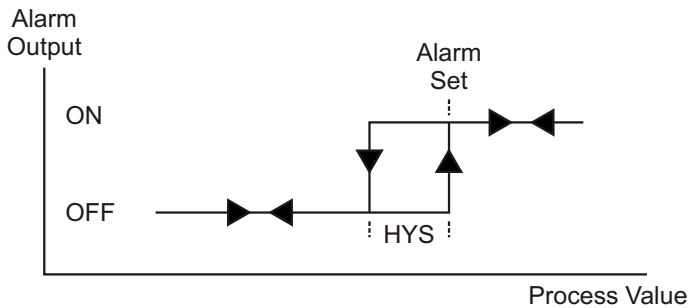

Process low alarm

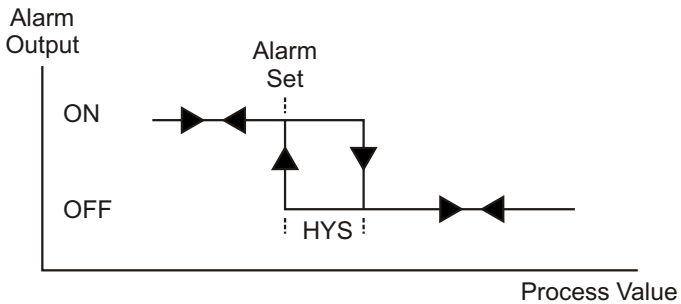

Lou3
0000

ALH3

Alarm- 3 hysteresis value. It is active if logic output function of Output-3 is alarm output.

It can be adjusted from 0% to 50% of process input scale
(uPL - LoL)

Aon3

Alarm on delay time. It can be adjusted from 0000 to 9999 seconds. It is active if logic output function of Output-3 is alarm output.

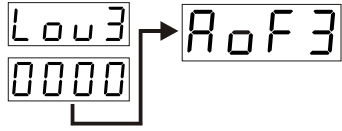

Alarm off delay time. It can be adjusted from 0000 to 9998 seconds. When the value is greater than 9998, `LECH` is seen on the display. It means alarm latching output is selected. It is active if logic output function of Output-3 is alarm output.

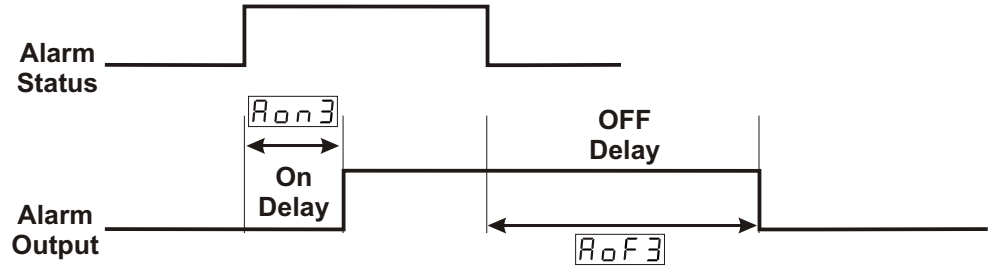

Gen
Conf

8.2.5 General Parameters

SU-L Minimum value for process set and alarm set values. It is named as low limit of set scale.

It can be adjusted from low limit of input selected with **,55L** parameter to **SU-U** parameter.

Please refer to Section 8.2.1 Process Input Type and Relevant Parameters with Process Input for **,55L** parameter

SU-U Maximum value for process set and alarm set values. It is named as high limit of set scale.

It can be adjusted from **SU-L** to high limit of input selected with **,55L** Parameter.

Please refer to Section 8.2.1 Process Input Type and Relevant Parameters with Process Input for **,55L** parameter

Con
Conf

8.2.6 Parameters for Configuration of Serial Communication

SAdr Communication Accessing Address

Communication accessing address of device. It can be adjusted from 1 to 247.

bAud Communication Baud Rate

0000 1200 Baud Rate

0001 2400 Baud Rate

0002 4800 Baud Rate

0003 9600 Baud Rate

0004 19200 Baud Rate

Prty Parity Selection for Communication

0000 No parity

0001 Odd Parity

0002 Even Parity

StPb Stop Bit Selection for Communication

0000 1 Stop Bit

0001 2 Stop Bits

PASS
CONF

8.2.7 Technician Password

ECPS It is used for accessing to the technician parameters.
It can be adjusted from 0 to 9999.

If it is 0000 ; there is no password protection while entering to the technician parameters.

If it is different from “ 0” and user wants to access to the technician parameters;

1- If user does not enter ECPS password correctly:

It turns to operation screen without entering to operator parameters.

2- When ECPS in top display and 0000 in bottom display, if user presses SET button without entering ECPS password (For observing parameters)

User can see all menus and parameters except Operator and Technician Password menu (“Pass Conf”) but parameters can not be changed.

(Please refer to Section 9. Failure Messages (4) in ESM-9900 Process Indicators)

9. Failure Messages in ESM-9900 Process Indicator

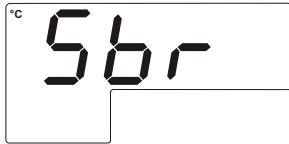

1 - Sensor failure in analogue inputs. Sensor connection is wrong or there is no sensor connection.

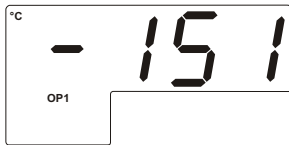

2 - If display blinks : If analogue input value is less than minimum value of operating scale \boxed{LoL} display starts to blink.



In "PinP Conf" Menu if;

\boxed{rSSL} $\boxed{0000}$; $\boxed{EC5L}$ $\boxed{0002}$; \boxed{unit} \boxed{C} ;
 \boxed{LoL} $\boxed{-199}$; \boxed{uPL} $\boxed{0900}$ are defined.

Adjust \boxed{LoL} $\boxed{-150}$

If analogue input value is less than minimum value of operating scale \boxed{LoL} Display starts to blink.



Please refer to Section 8.2.1 for detailed information about this parameter.



3 - If display blinks : If analogue input value is greater than maximum value of operating scale \boxed{uPL} , display starts to blink.



In "PinP Conf" Menu ;

\boxed{rSSL} $\boxed{0000}$; $\boxed{EC5L}$ $\boxed{0002}$; \boxed{unit} \boxed{C} ;
 \boxed{LoL} $\boxed{-199}$; \boxed{uPL} $\boxed{0900}$

Adjust \boxed{uPL} $\boxed{0850}$

If analogue input value is greater than maximum value of operating scale \boxed{uPL} , display starts to blink.



Please refer to Section 8.2.1 for detailed information about this parameter.



4 - If technician password is different from "0" and user accesses to the parameter by Set button without entering the technician password and wants to change a parameter, the warning message is shown on the bottom display as shown on the left. Device does not allow to do any changes without entering the password correctly.

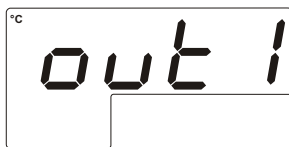
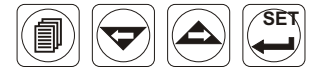
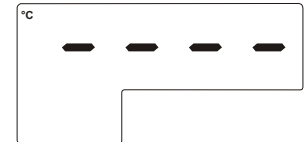

5 - If user does not do anything for 120 seconds while device is on Set or Technician menus, device turns to operation screen.



10. Specifications

Device Type	: Process Indicator
Housing&Mounting	: 96mm x 96mm x 87.5mm 1/4 DIN 43700 plastic housing for panel mounting. Panel cut-out is 92x92mm. Type-1 Enclosure Mounting.
Protection Class	: NEMA 4X (IP65 at front, IP20 at rear).
Weight	: Approximately 0.34 Kg.
Environmental Ratings	: Standard, indoor at an altitude of less than 2000 meters with none condensing humidity.
Storage/Operating Temperature	: -40 °C to +85 °C / 0 °C to +50 °C
Storage/Operating Humidity	: 90 % max. (None condensing)
Installation	: Fixed installation
Over Voltage Category	: II
Pollution Degree	: II, office or workplace, none conductive pollution
Operating Conditions	: Continuous
Supply Voltage and Power	: 100 - 240 V ~ (-15% / +10%) 50/60 Hz. 6VA 24 V ~ (-15% / +10%) 50/60 Hz. 6VA 24 V == (-15% / +10%) 6W
Process Inputs	: Universal input TC, RTD, ==Voltage/Current
Thermocouple Input Types	: Selectable by parameters L (DIN43710) , J ,K ,R ,S ,T ,B ,E ,N (IEC584.1)(ITS90) , C (ITS90)
Thermoresistance Input Types	: PT 100 (IEC751) (ITS90)

=== Voltage Input Types	: Selectable by parameters 0...50mV ===, 0...5V ===, 0...10V ===
=== Current Input Types	: Selectable by parameters 0...20mA ===, 4...20mA ===
Accuracy	: ± 0,25% of full scale for thermocouple, thermoresistance and voltage, ± 0,70% of full scale for current.
Cold Junction Compensation	: Automatically ± 0.1°C/1°C.
Line Compensation	: Maximum 10 .
Sensor Break Protection	: Upscale
Sampling Cycle	: 3 samples per second
Input Filter	: 0.0 to 900.0 seconds
Control Forms	: Programmable ON / OFF.
Standard Relay Output	: 5A@250V~ (Programmable control or alarm output) (Electrical Life : 100.000 Operation (Full Load))
Output Modules	: -EMO-900 Relay Output Module (5A@250V~) -EMO-910 SSR Driver Output Module (Max.26mA, Max. 22V ===) -EMO-920 Digital (Transistor) Output Module (Max 40mA@18V ===) -EMO-930 0/4...20mA === Current Output Module
Standard Communication Module	: EMC-900 RS-232 Communication Module
Optional Communication Module	: EMC-910 RS-485 Communication Module
Communication Protocol	: MODBUS-RTU
Process Display	: 14 mm Red 4 digit LED display
Led Indicators	: O1 / 2 / 3 (Outputs) LEDs, °C / °F / V unit LEDs
Approvals	: UL Recognized Component (File No : E 254103), ENEC, CE

10. Other Informations

Manufacturer Information:

Emko Elektronik Sanayi ve Ticaret A.Ş.
Demirtaş Organize Sanayi Bölgesi Karanfil Sk. No:6 16369
BURSA/TURKEY

Phone : +90 224 261 1900
Fax : +90 224 261 1912

Repair and Maintenance Service Information:

Emko Elektronik Sanayi ve Ticaret A.Ş.
Demirtaş Organize Sanayi Bölgesi Karanfil Sk. No:6 16369
BURSA/TURKEY

Phone : +90 224 261 1900
Fax : +90 224 261 1912



Thank you very much for your preference to use Emko Elektronik Products.

www.emkoelektronik.com.tr